

# Decatur, Georgia Streetscape Guidelines

**DRAFT** November 5, 2014





# STREETSCAPE GUIDELINES

- Introduction .....S-3**
  - Goals of the City of Decatur’s Streetscape Guidelines ..... S-3
- Layout .....S-5**
  - Typical Layout Notes..... S-5
  - Typical Streetscape Layout ..... S-6
  - Typical Street Furniture Layout..... S-7
  - Typical Street Furniture Layout..... S-8
- Accessibility ..... S-9**
  - Handicap Ramp at Curb ..... S-9
  - Handicap Parking Space Striping..... S-10
  - Handicap Sign Placement..... S-11
  - Handicap Parking Sign ..... S-12
- Paving ..... S-13**
  - Driveway Apron..... S-13
  - Standard Concrete Curb..... S-14
  - Street Patch Detail at Curb ..... S-15
  - Sidewalk and Tree Well Plan..... S-16
  - Expansion Joint Detail..... S-17
  - Contraction Joint Detail ..... S-18
  - Trench Repair ..... S-19
  - Standard Residential Road Section..... S-20
  - Standard Mixed-Use/Commercial Road Section ..... S-21
  - Standard Alley Road Section..... S-22
- Site Furnishings ..... S-23**
  - Typical Bench Details..... S-23
  - Wheel Stop..... S-24
  - Trash Receptacle and Connection ..... S-25
  - Bicycle Rack..... S-26
  - Ornamental Pedestrian Lights ..... S-27
- Plantings..... S-29**
  - Groundcover and Perennials ..... S-29
  - Triangular Plant Spacing..... S-30
  - Sidewalk Tree Well Section..... S-31
  - Parking Area Tree Well Section ..... S-32
  - Temporary Tree Protection..... S-33
  - Root Barrier Details..... S-34

|   |             |
|---|-------------|
| Tree Staking Standards .....  | S-35        |
| Appropriate Plant Selections .....                                  | S-36        |
| <b>Drainage .....</b>   | <b>S-39</b> |
| Curved Bicycle Safety Gate .....                                    | S-39        |
| Sidewalk Flume with Plate and Sidewalk Trench Frame and Grate ..... | S-40        |
| Flared End Section .....  | S-41        |
| Traffic Rated Manhole Frame and Cover Assembly .....                | S-42        |
| Non-Traffic Rated Manhole Frame and Cover Assembly .....            | S-43        |
| Bioswale Planter Detail .....                                       | S-44        |
| Bioswale Planter Curb Openings Detail .....                         | S-45        |
| Bioswale Planter Notes .....  | S-46        |

## Introduction

The purpose of this booklet is to aid future private investors in Downtown Decatur in preparing physical designs which are in harmony with the intent and character of existing conditions in the area. It is hoped that a visually pleasing and unified business district will result from the repeated use of common details, layouts, plant selections, and site furnishings. You will find in this publication a collection of design guidelines that will assist you in designing a streetfront area that will enhance your business and community.

### Goals of the City of Decatur's Streetscape Guidelines

- Provide a high impact vision that is respectful of Downtown Decatur's history and character.
- Design a cost-effective, long term solution that enjoys maximum visual impact.
- Encourage funding commitments from public agencies and private investors alike.
- Guide the implementation and maintenance of enhancements in Downtown Decatur and the City's Neighborhood Business Districts.

For additional information contact:

#### Design Environmental and Construction Division

City of Decatur  
2635 Talley Street  
Decatur, Georgia 30030  
tel: 404-370-4104

This page intentionally left blank.

# Layout







## Typical Layout Notes

- A.** All dimensions to face of curb, building, wall, etc, unless otherwise noted.
- B.** All dimensions are parallel or perpendicular to the elements from which they are measured, unless otherwise indicated on drawings.
- C.** All new sidewalks shall be constructed in a manner that provides positive drainage away from all buildings and toward streets at a slope of 1/4" per foot. Some warping around existing fixed elements may be required.
- D.** Where new paving meets existing paving, contractor shall match existing line and grade.
- E.** Contractor shall match existing grades along right-of-way, at the face of all structures and/or at the limit of work.
- F.** All utility valves, manholes, meter boxes, etc. shall be adjusted to final elevation by the contractor. Contractor to coordinate with local utility providers to determine if the provider will adjust their facility.
- G.** All paved areas are to be constructed in such a manner as to prevent the ponding of water and allow for positive drainage. Minimum slope on sidewalks shall be 1.5% to a Maximum of 3.0%.
- H.** Contractor to coordinate with all utility providers regarding construction schedule, location of all existing service lines, construction of new utility services and coordination/scheduling of related work prior to beginning streetscape work.
- I.** Contractor shall have utility locator service locate all utilities in project area prior to beginning construction.
- J.** Contractor to layout typical concrete scoring pattern (5'x5'+Grid) as indicated in guidelines. Where existing conditions do not allow a 5'x5' pattern, contractor shall consult with the Design Environment and Construction Division for direction.
- K.** Street trees and lights are typically to be centered in the 5'x5' grid. Lights are occasionally located on joint lines and should also be centered between transverse joints on the joint line.
- L.** All ornamental pedestrian lights, associated footings and wiring shall be provided by Georgia Power. Contractor shall be responsible for coordinating the sequencing of the projects with Georgia Power. See product information regarding the City of Decatur's standard fixture.
- M.** Stormwater drainage shall meet Georgia Department of Transportation (GDOT) standard specifications and details.

# Layout

## Typical Streetscape Layout

### LEGEND:

-  CONCRETE CURB (SEE STD. 301 & 302)
-  CONCRETE SIDEWALK (SEE STD. 303)
-  HANDICAP RAMP (SEE STD. 200)
-  ORNAMENTAL PEDESTRIAN LIGHT (SEE STD. 404)
-  STREET TREE
-  TREE WELL AND/OR BIOSWALE PLANTER WITH GROUND COVER (SEE STD. 303 & 606)
-  DRIVEWAY APRON (SEE STD. 300)

NOTE:  
 BENCHES (STD. 400), BIKE RACKS (STD. 403), AND TRASH RECEPTACLES (STD. 402) SHALL BE LOCATED AS DIRECTED BY THE CIT OF DECATUR.

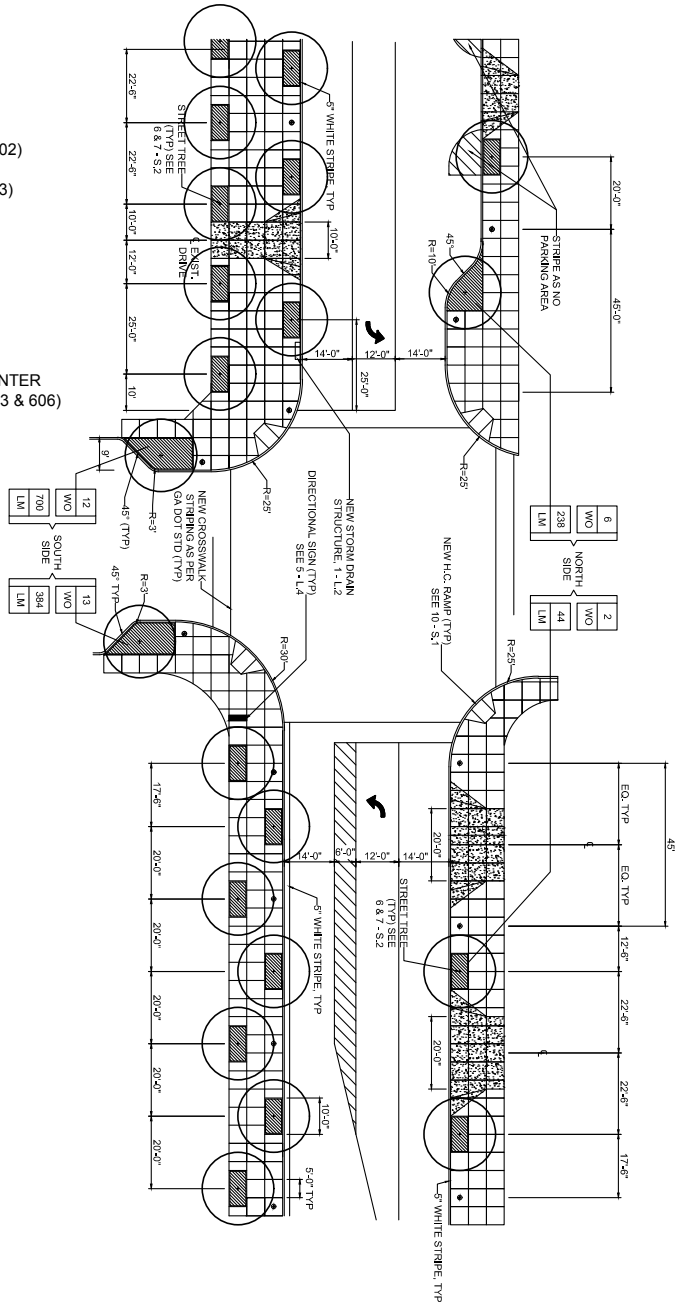

## DECATUR STREETScape GUIDELINES DOWNTOWN DECATUR

### TYPICAL STREETScape LAYOUT

SCALE: NONE

DRAFT DATE:  
 07/03/2014  
 STANDARD NO:  
**100**



# Layout

## Typical Street Furniture Layout

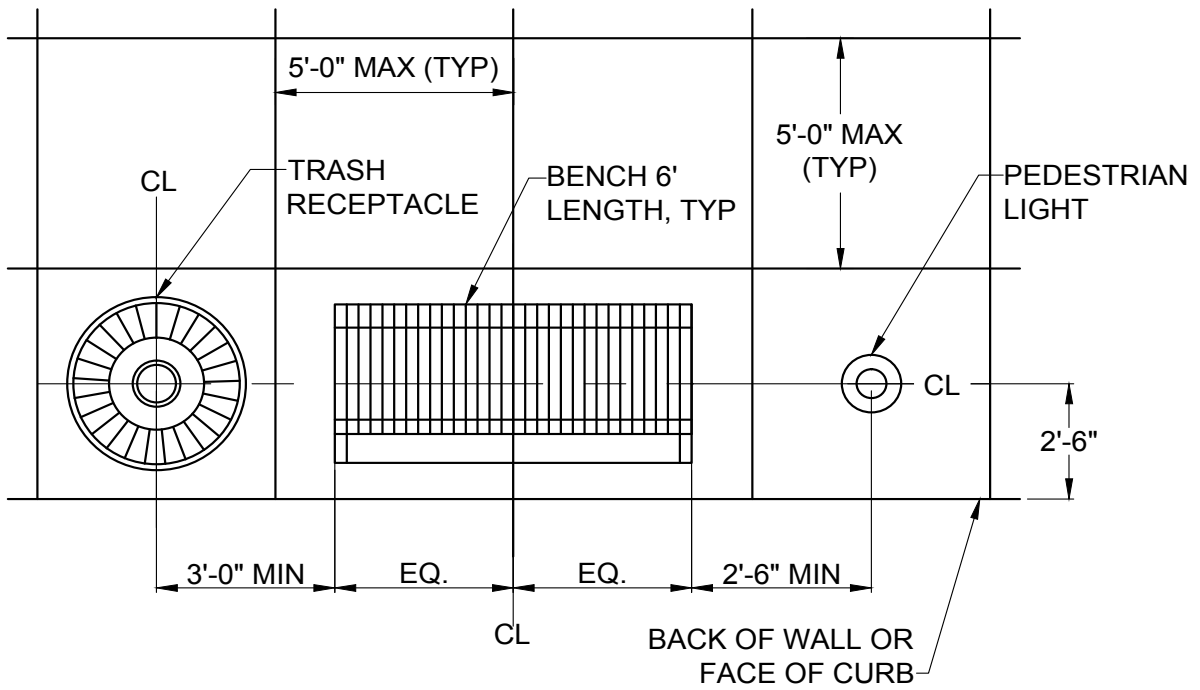

DECATUR STREETScape GUIDELINES  
 DOWNTOWN DECATUR

TYPICAL STREET FURNITURE LAYOUT

SCALE: NONE

DRAFT DATE:  
07/03/2014

STANDARD NO:  
**101**

# Layout

## Typical Street Furniture Layout



Photographs of Typical Furniture Layout

# Accessibility

## Handicap Ramp at Curb

**ACCEPTABLE ADA RAMPS:**

GDOT ENGLISH CONSTRUCTION DETAIL A3 TYPES A, B, AND D. CONCRETE FOR RAMPS SHALL BE A MINIMUM THICKNESS OF 4 INCHES AND A MINIMUM THICKNESS OF 8 INCHES AT INTERSECTIONS.

SEE GDOT ENGLISH CONSTRUCTION DETAIL A3 FOR DETAILS OF RAMPS AND THEIR LOCATIONS AT INTERSECTIONS

DETECTABLE WARNING SURFACES ARE REQUIRED ON ALL INTERSECTIONS WITH PUBLIC STREETS, SIGNALIZED COMMERCIAL DRIVEWAYS, AND COMMERCIAL DRIVEWAYS WITH AN AADT OF 25 VEHICLES/DAY

**DETECTABLE WARNING SURFACE:**

**DETAIL:**

SEE GDOT ENGLISH CONSTRUCTION DETAIL A4

**SIZE:**

DETECTABLE WARNINGS SHALL BE 24 INCHES (610 mm) IN THE DIRECTION OF PEDESTRIAN TRAVEL AND EXTEND THE FULL WIDTH OF THE CURB RAMP OR FLUSH SURFACE.

**LOCATION:**

THE DETECTABLE WARNING SHALL BE LOCATED SO THAT THE EDGE NEAREST THE CURB LINE OR OTHER POTENTIAL HAZARD IS 6 TO 8 INCHES (150 mm TO 180 mm) FROM THE CURB LINE OR OTHER POTENTIAL HAZARD, SUCH AS A REFLECTIVE POOL EDGE OR THE DYNAMIC ENVELOPE OF RAIL OPERATIONS.

**DOMES SIZE AND SPACING:**

TRUNCATED DOMES SHALL HAVE A BASE DIAMETER OF 0.9 INCH TO 1.4 INCH (23 mm-36 mm) AT THE BOTTOM, A DIAMETER OF 0.45 INCH TO 0.9 INCH (11mm-23 mm) AT THE TOP, THE TOP DIAMETER SHALL BE A MINIMUM OF 50% AND A MAXIMUM OF 65% OF THE BASE DIAMETER, A HEIGHT OF 0.2 INCH (5.11 mm) AND A CENTER-TO-CENTER SPACING OF 2.40 INCHES (61mm) DESIRABLE 1.60 INCHES (41 mm) MINIMUM MEASURED ALONG ONE SIDE OF A SQUARE ARRANGEMENT. DOMES SHALL BE ALIGNED ON A SQUARE GRID IN THE PREDOMINANT DIRECTION OF TRAVEL TO PERMIT WHEELS TO ROLL BETWEEN DOMES.

**VISUAL CONTRAST:**

DETECTABLE WARNING SURFACES SHALL CONTRAST VISUALLY WITH THE ADJACENT WALKING SURFACE EITHER LIGHT-ON-DARK OR DARK-ON-LIGHT. THE MATERIAL USED TO PROVIDE VISUAL CONTRAST SHALL BE AN INTEGRAL PART OF THE DETECTABLE WARNING SURFACE.

**MATERIALS:**

SOURCE: ADA SOLUTIONS, P.O. BOX 3 N. BILLERICA, MA 01862

**NEW CONSTRUCTION:**

ADA COMPOSITE REPLACEABLE CAST IN PLACE (WET SET) OR APPROVED EQUAL.

**RETROFIT:**

ADA DETECTABLE WARNING TILE OR APPROVED EQUAL.

**INSTALLATION:**

INSTALL IN ACCORDANCE WITH MANUFACTURER'S SPECIFICATIONS AS INDICATED ON GDOT ENGLISH CONSTRUCTION DETAIL A4.

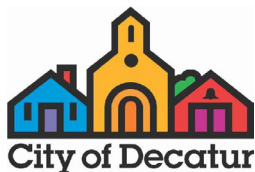

DECATUR STREETScape GUIDELINES  
DOWNTOWN DECATUR

HANDICAP RAMP AND DETECTABLE WARNING SURFACE

SCALE: NONE

DRAFT DATE:  
07/03/2014

STANDARD NO:  
**200**

# Accessibility

## Handicap Parking Space Striping

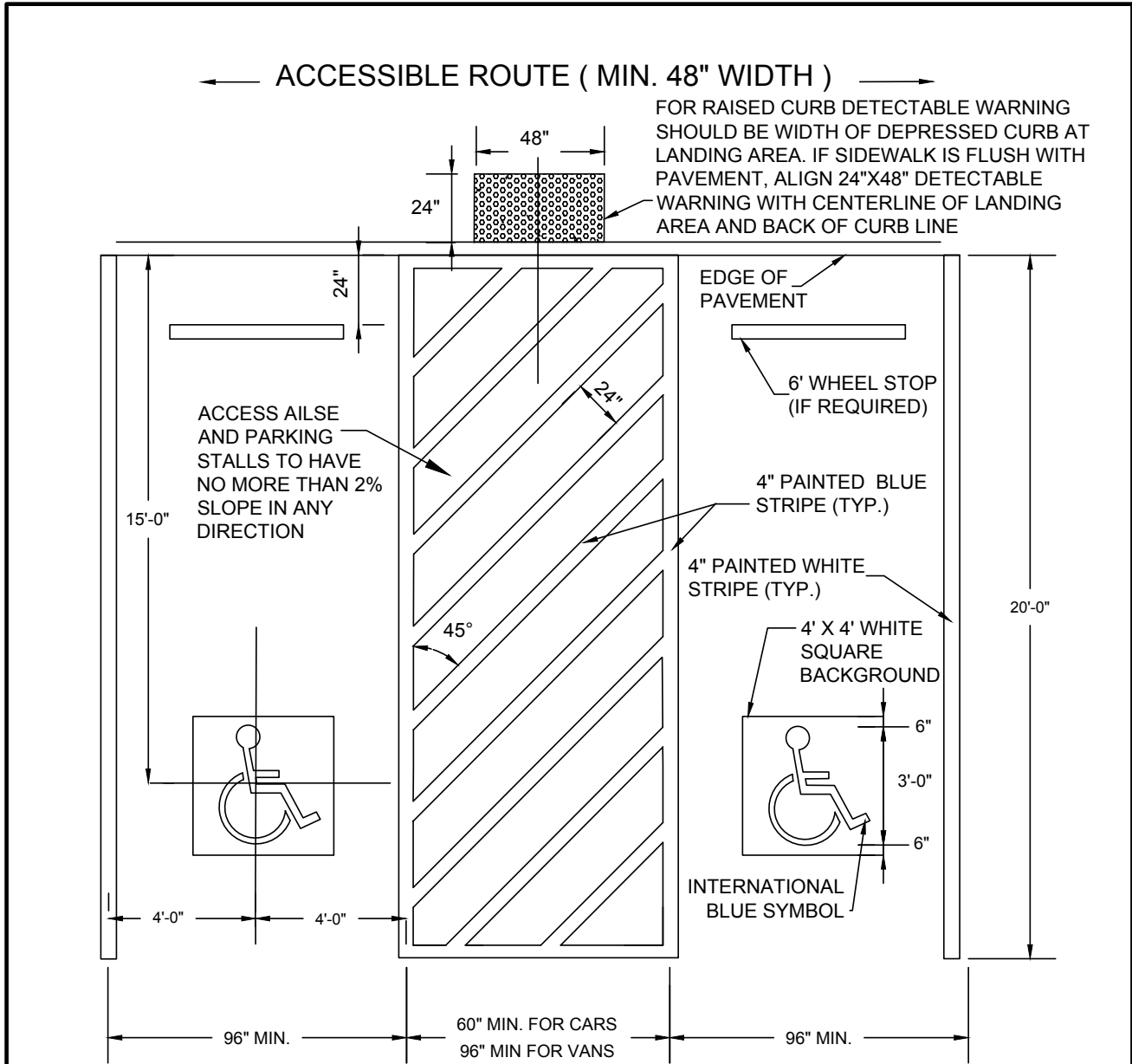

NOTE:

1. STRIPING AND CONSTRUCTION SHALL CONFORM TO ALL APPLICABLE FEDERAL, STATE AND CITY OF DECATUR CODES AND SPECIFICATIONS.
2. ALL PAVEMENT MARKINGS AND STRIPING IN THE RIGHT-OF-WAY SHALL BE THERMOPLASTIC.

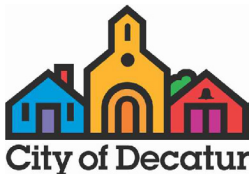

### DECATUR STREETScape GUIDELINES DOWNTOWN DECATUR

### HANDICAP PARKING SPACE STRIPING

SCALE: NONE

DRAFT DATE:  
07/03/2014

STANDARD NO:

201

# Accessibility

## Handicap Sign Placement

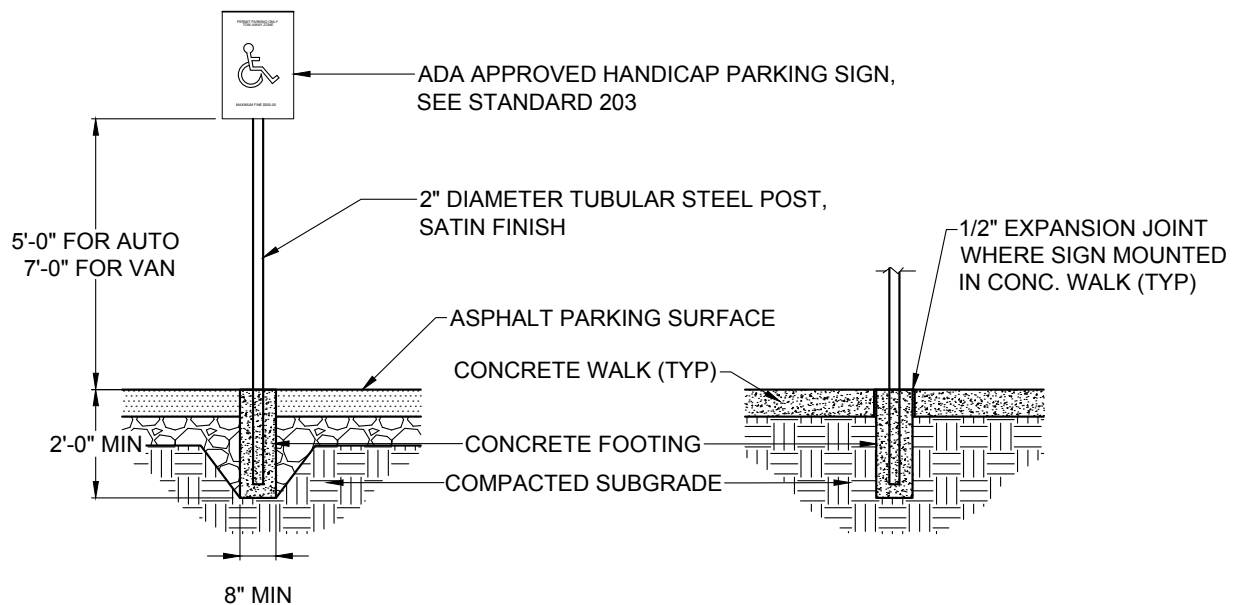

**NOTE:**

SIGNAGE SHALL CONFORM TO ALL APPLICABLE  
FEDERAL, STATE AND CITY OF DECATUR CODES  
AND SPECIFICATIONS

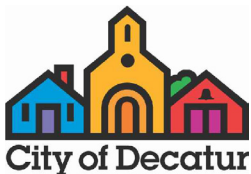

DECATUR STREETScape GUIDELINES  
DOWNTOWN DECATUR

HANDICAP SIGN PLACEMENT

SCALE: NONE

DRAFT DATE:  
07/03/2014

STANDARD NO:

**202**

# Accessibility

## Handicap Parking Sign

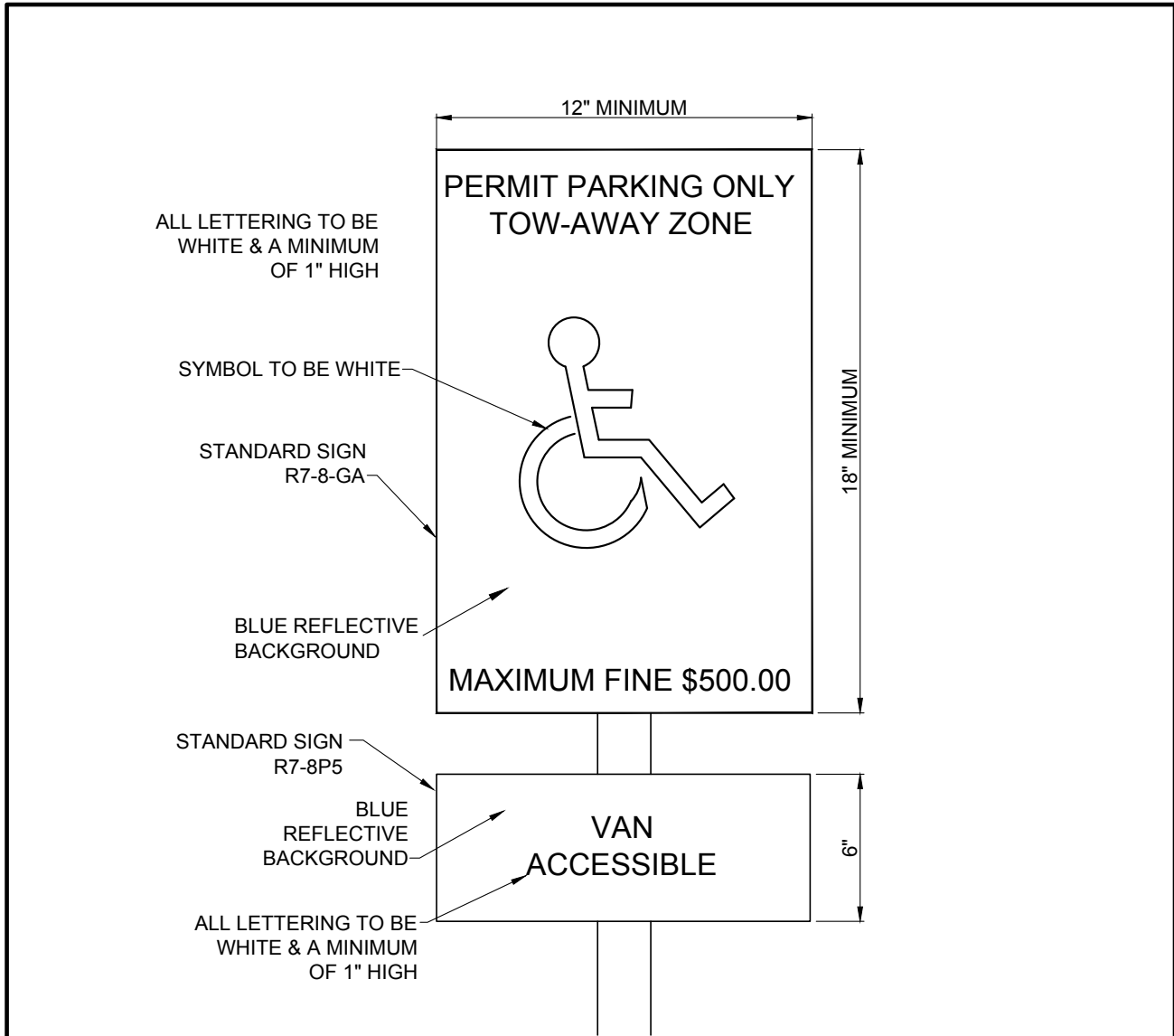

1. ALL SIGNS TO BE 0.080" THICK ALUMINUM.
2. ALL SIGNS SHALL CONFORM WITH ALL CURRENT A.D.A FEDERAL, STATE, AND LOCAL CODES & REGULATIONS.
3. PLACE "VAN ACCESSIBLE" SIGN IN FRONT OF VAN ACCESSIBLE SPACES ONLY.

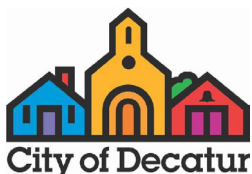

### DECATUR STREETSCAPE GUIDELINES DOWNTOWN DECATUR

#### HANDICAP PARKING SIGN

SCALE: NONE

DRAFT DATE:  
07/03/2014

STANDARD NO:

**203**



# Paving

## Standard Concrete Curb

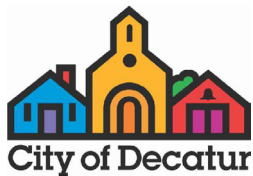
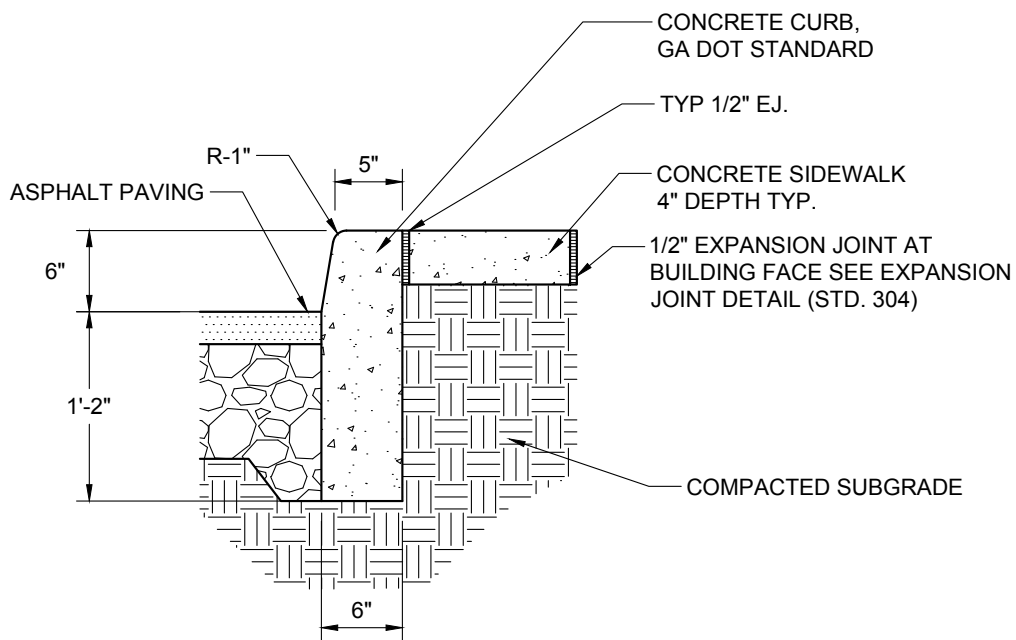

### DECATUR STREETScape GUIDELINES DOWNTOWN DECATUR

#### STANDARD CONCRETE CURB

SCALE: NONE

DRAFT DATE:  
07/03/2014

STANDARD NO:

**301**



# Paving

## Street Patch Detail at Curb

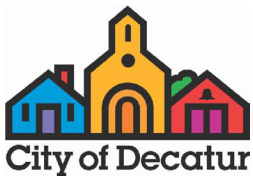
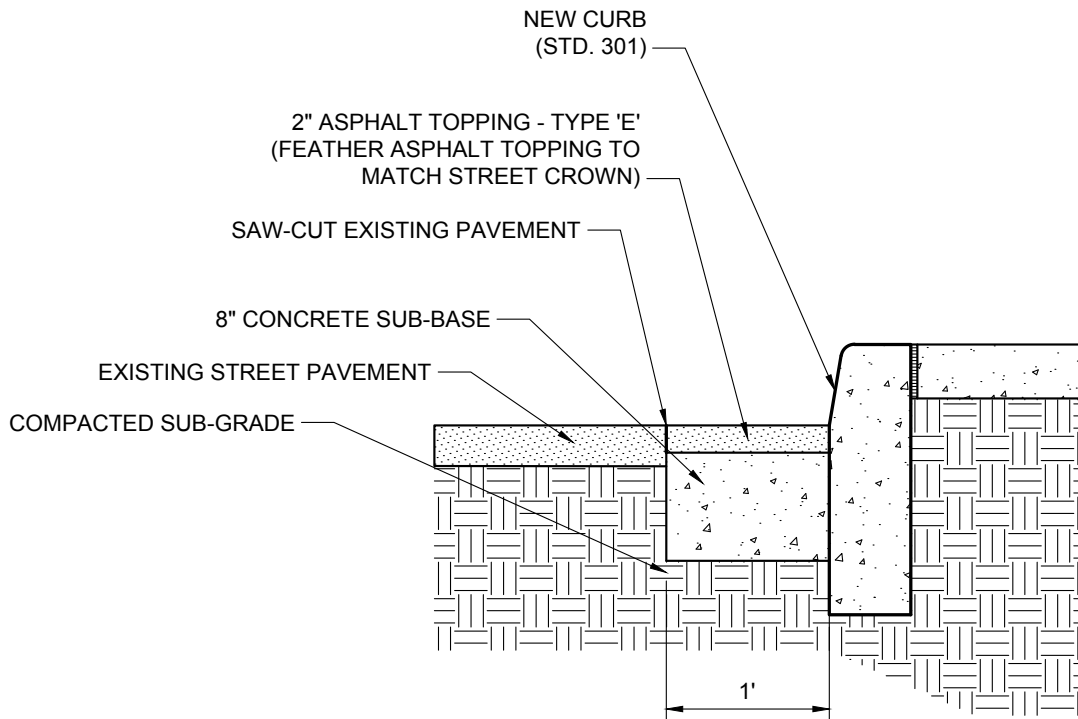

### DECATUR STREETScape GUIDELINES DOWNTOWN DECATUR

#### STREET PATCH DETAIL AT CURB

SCALE: NONE

DRAFT DATE:  
07/03/2014

STANDARD NO:

**302**



# Paving

## Expansion Joint Detail

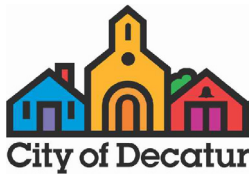
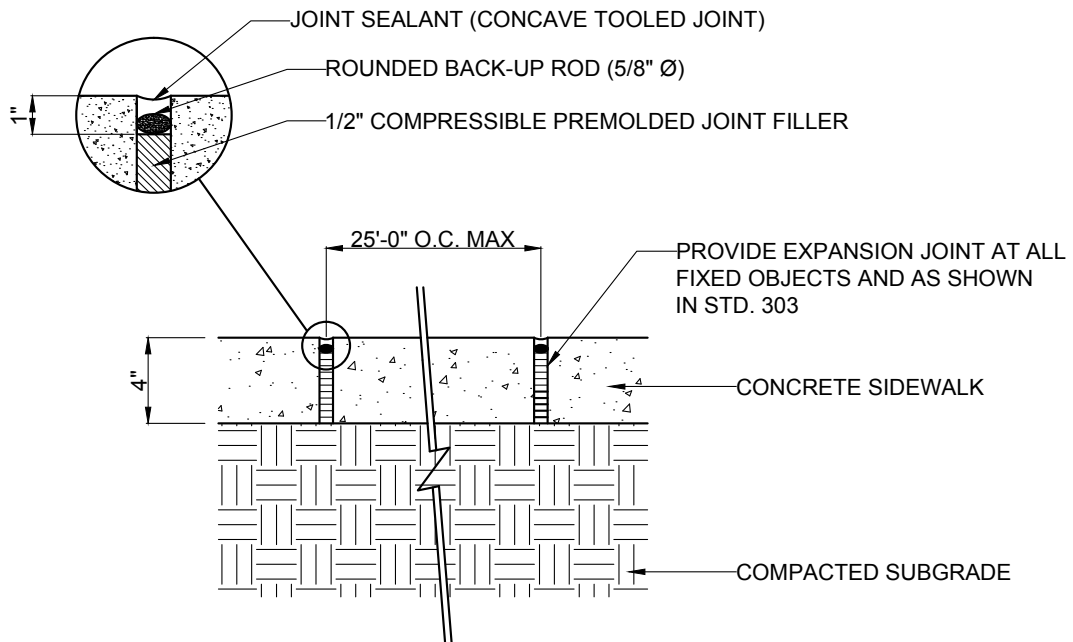

### DECATUR STREETSCAPE GUIDELINES DOWNTOWN DECATUR

#### EXPANSION JOINT DETAIL

SCALE: NONE

DRAFT DATE:  
07/03/2014

STANDARD NO.:

**304**

# Paving

## Contraction Joint Detail

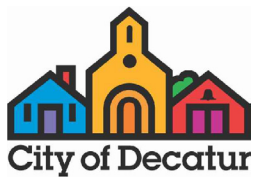
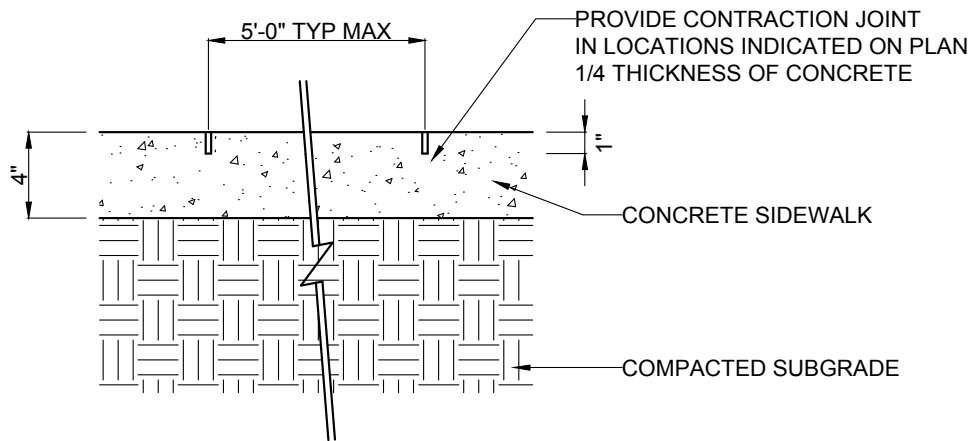

### DECATUR STREETScape GUIDELINES DOWNTOWN DECATUR

#### CONTRACTION JOINT DETAIL

SCALE: NONE

DRAFT DATE:  
07/03/2014

STANDARD NO:

**305**

# Paving

## Trench Repair

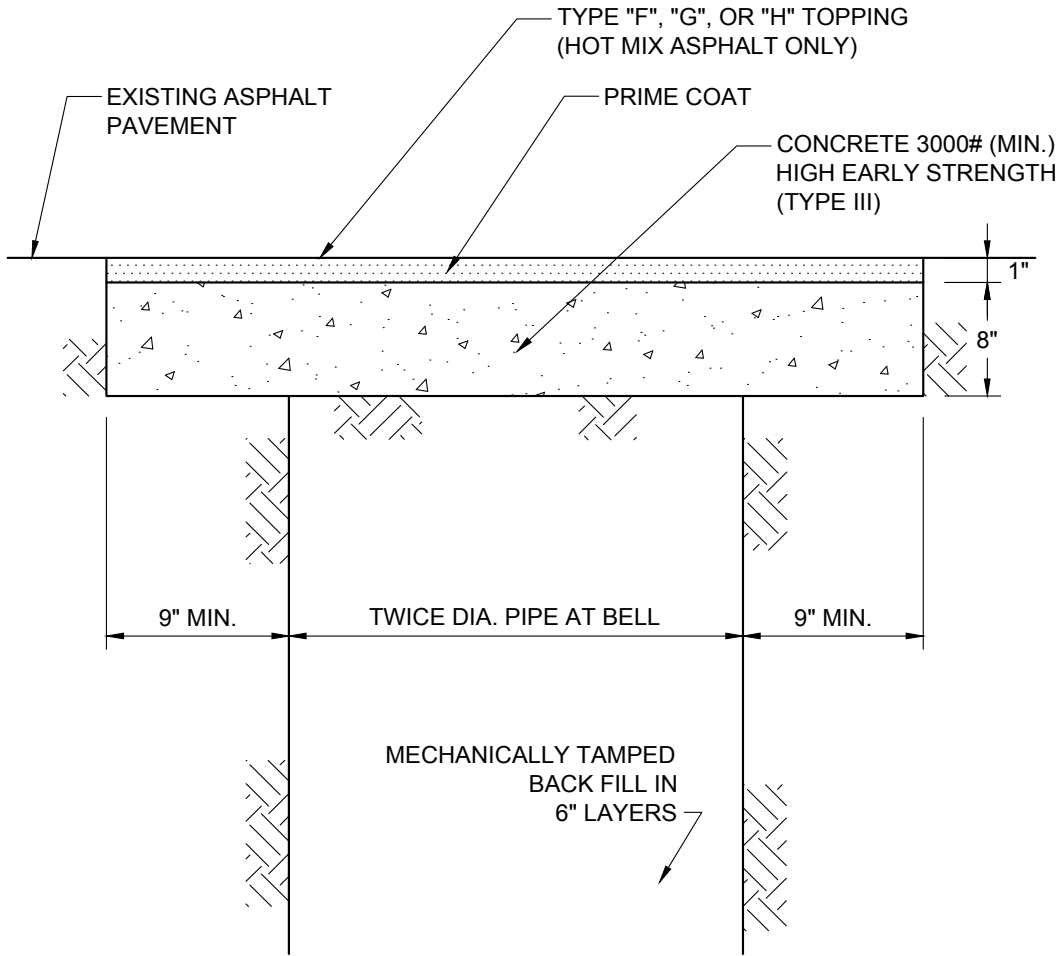

1. EXIST. ASPH. MUST BE SAW CUT TO NEAT STRAIGHT LINES.
2. ALL EDGES OF FINISH ASPHALT MUST BE STRAIGHT. RAGGED EDGES WILL NOT BE ACCEPTABLE
3. ALL CUTS SHALL BE SQUARED UP, WITH PARALLEL SIDES, INCLUDING CUTS AT M.H.

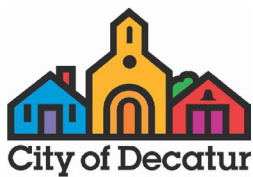

### DECATUR STREETScape GUIDELINES DOWNTOWN DECATUR

#### TRENCH REPAIR

SCALE: NONE

DRAFT DATE:  
07/03/2014

STANDARD NO:

**306**

# Paving

## Standard Residential Road Section

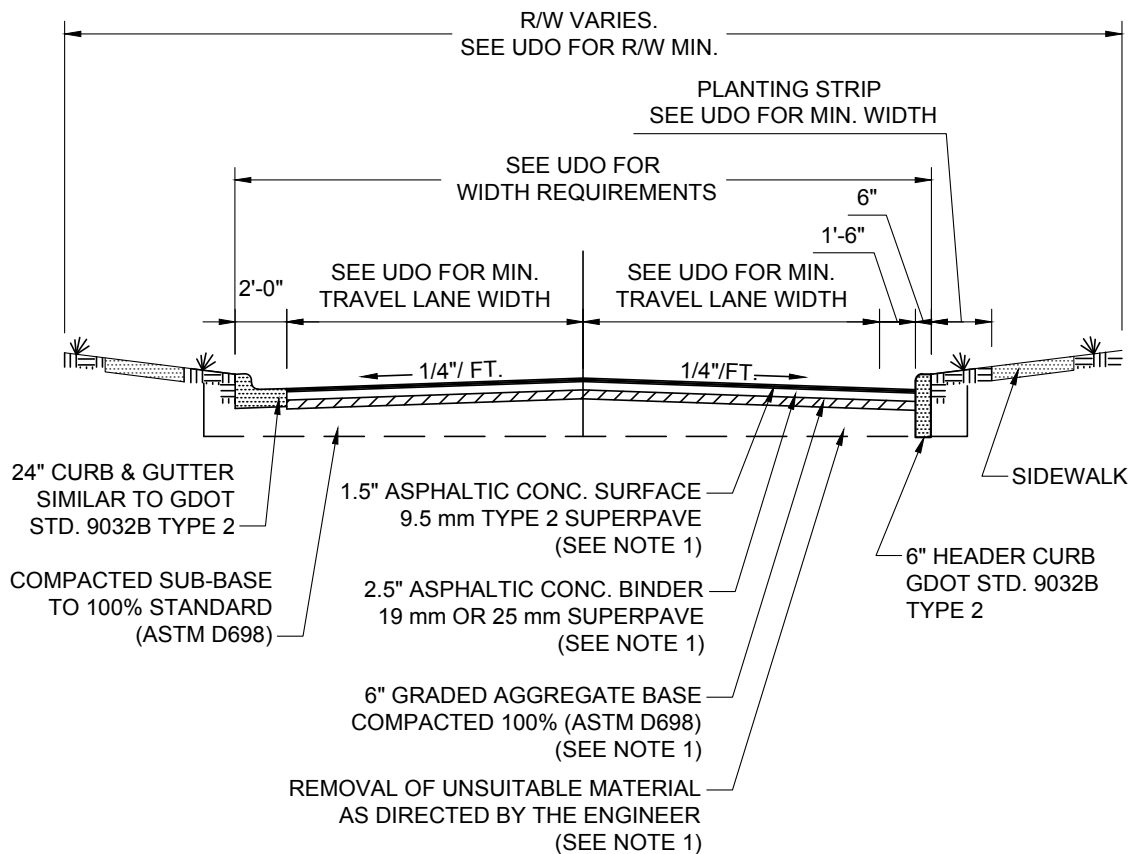

**NOTES:**

1. PAVEMENT SECTIONS SHALL BE APPROVED BY CITY OF DECATUR FOR EACH SPECIFIC PROJECT.

UDO = UNIFIED DEVELOPMENT ORDINANCE

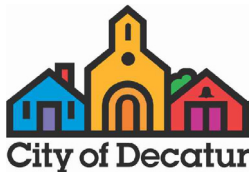

DECATUR STREETScape GUIDELINES  
DOWNTOWN DECATUR

STANDARD RESIDENTIAL ROAD SECTION

SCALE: NONE

DRAFT DATE:  
07/03/2014

STANDARD NO:

**307**

# Paving

## Standard Mixed-Use/Commercial Road Section

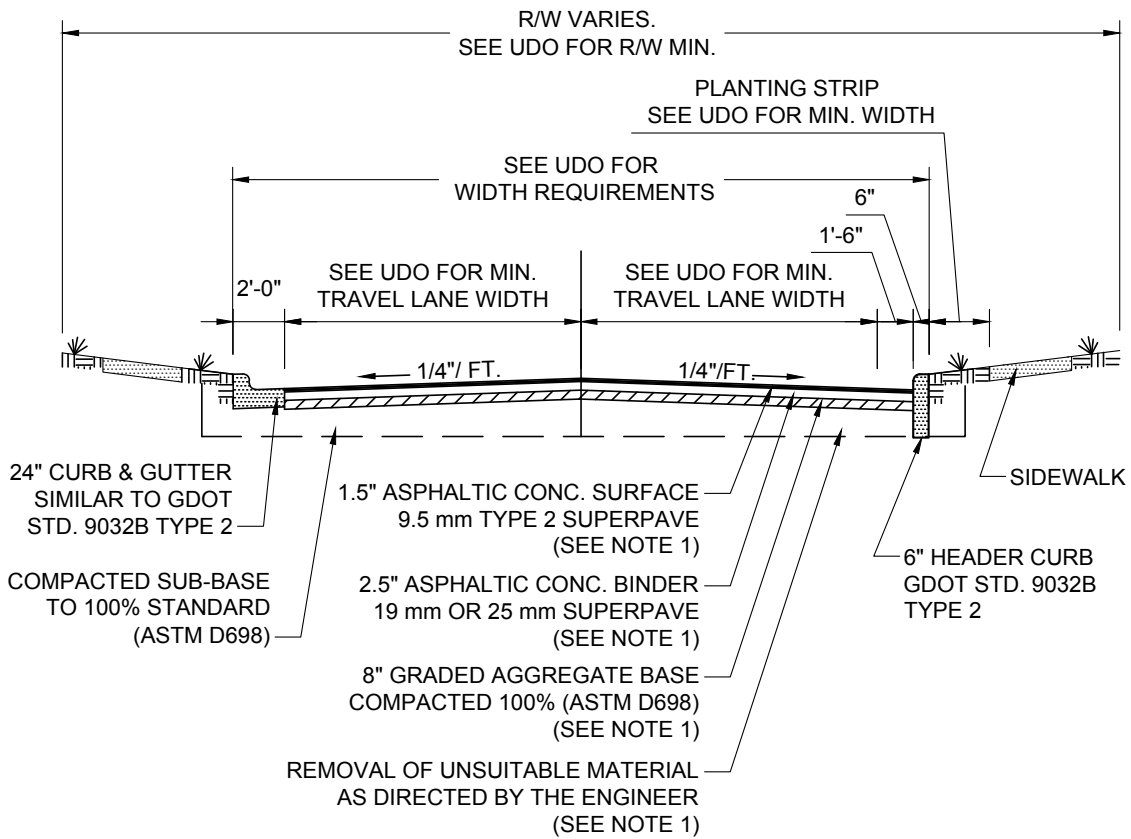

NOTES:  
1. PAVEMENT SECTIONS SHALL BE APPROVED BY  
CITY OF DECATUR FOR EACH SPECIFIC PROJECT.

UDO = UNIFIED DEVELOPMENT ORDINANCE

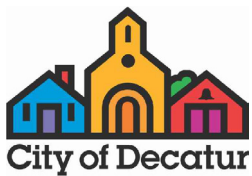

### DECATUR STREETSCAPE GUIDELINES DOWNTOWN DECATUR

#### STANDARD MIXED USE/COMMERCIAL ROAD SECTION

SCALE: NONE

DRAFT DATE:  
07/03/2014

STANDARD NO:

**308**

# Paving

## Standard Alley Road Section

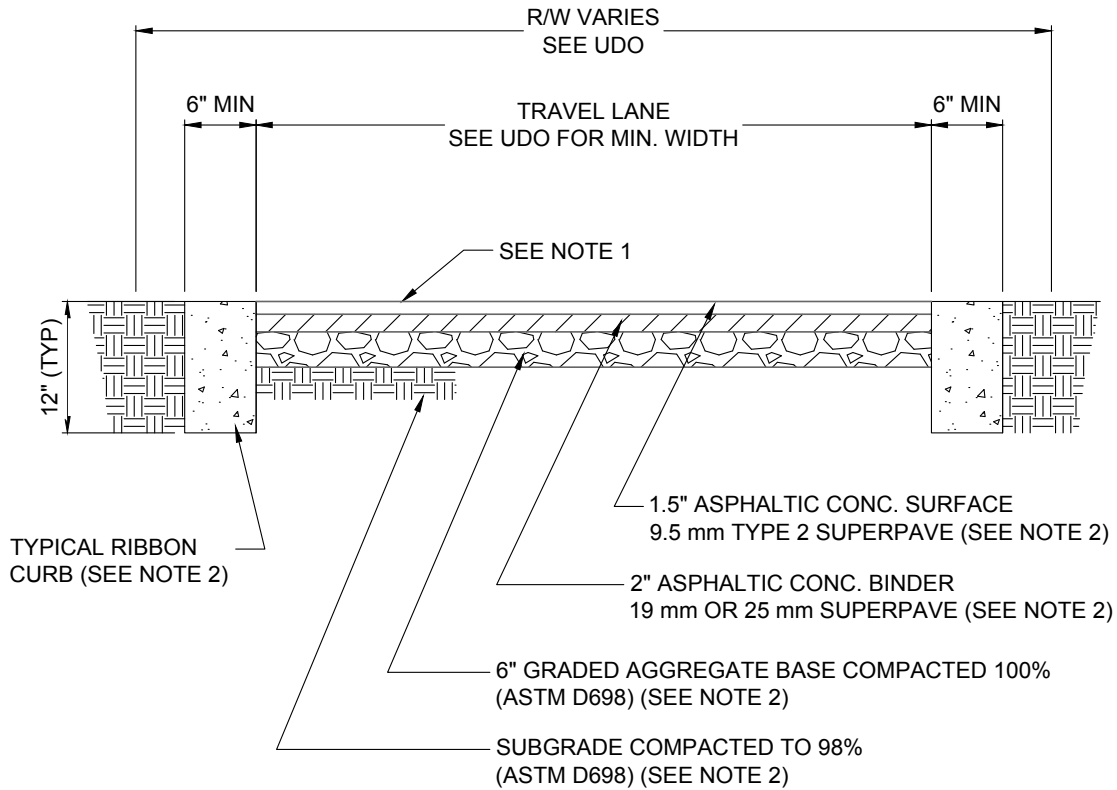

**NOTES:**

1. ASPHALT PAVEMENT SECTION SHOWN; HOWEVER, ALTERNATE PAVEMENT MATERIAL MAY BE USED IF APPROVED BY CITY.
2. PAVEMENT SECTIONS SHALL BE APPROVED BY CITY OF DECATUR FOR EACH SPECIFIC PROJECT.
3. RIBBON CURB NOT REQUIRED IF ALLEY IS CONCRETE PAVEMENT.
4. DETAIL SHOWS MINIMUM THICKNESS FOR ASPHALT PAVEMENT SECTION. DESIGNER SHALL VERIFY IF PAVEMENT SECTION IS ADEQUATE FOR ACTUAL VEHICULAR TRAFFIC THAT WILL ACCESS ALLEY.
5. PAVEMENT SECTION DOES NOT CONSIDER EMERGENCY VEHICLE TRAFFIC.
6. RIBBON CURB SHALL BE A MINIMUM OF 3000 PSI CONCRETE AT 28 DAYS.
7. ALONG RIBBON CURB:
  - 1/2-INCH EXPANSION JOINTS OR PREMOLDED BITUMINOUS EXPANSION JOINT MATERIAL SHALL BE PROVIDED AT ALL STRUCTURES, RADIUS POINTS, AND AT INTERVALS NOT TO EXCEED 50 FEET.
  - CONTRACTION JOINT SHALL BE INSTALLED 1/2-INCH AT 10-FT INTERVALS.

UDO = UNIFIED DEVELOPMENT ORDINANCE



DECATUR STREETScape GUIDELINES  
DOWNTOWN DECATUR

STANDARD ALLEY ROAD SECTION

SCALE: NONE

DRAFT DATE:  
07/03/2014

STANDARD NO:

309



# Site Furnishings

## Typical Bench Details

Bench:

A. Model C-10 by Victor Stanley, Inc.  
 6' Length Mahogany, Dunkir, Maryland 20754

B. Finish: Standard  
 Color: Black

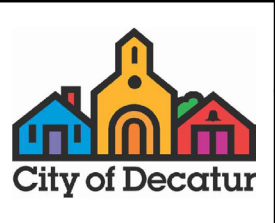
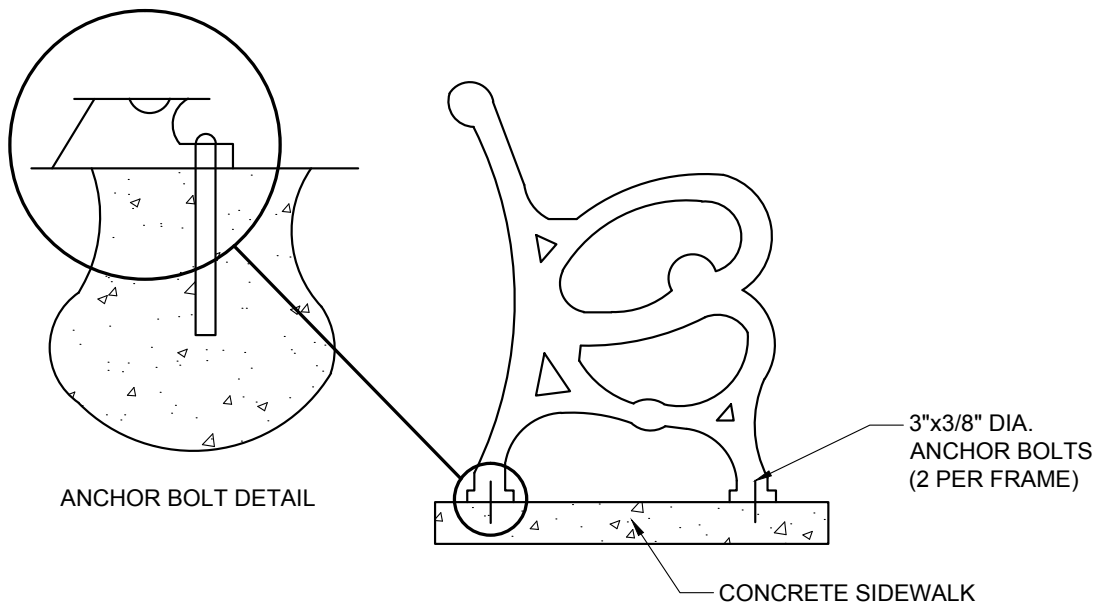

### DECATUR STREETScape GUIDELINES DOWNTOWN DECATUR

#### BENCH DETAIL

SCALE: NONE

DRAFT DATE:  
 07/03/2014

STANDARD NO:  
**400**

# Site Furnishings

## Wheel Stop

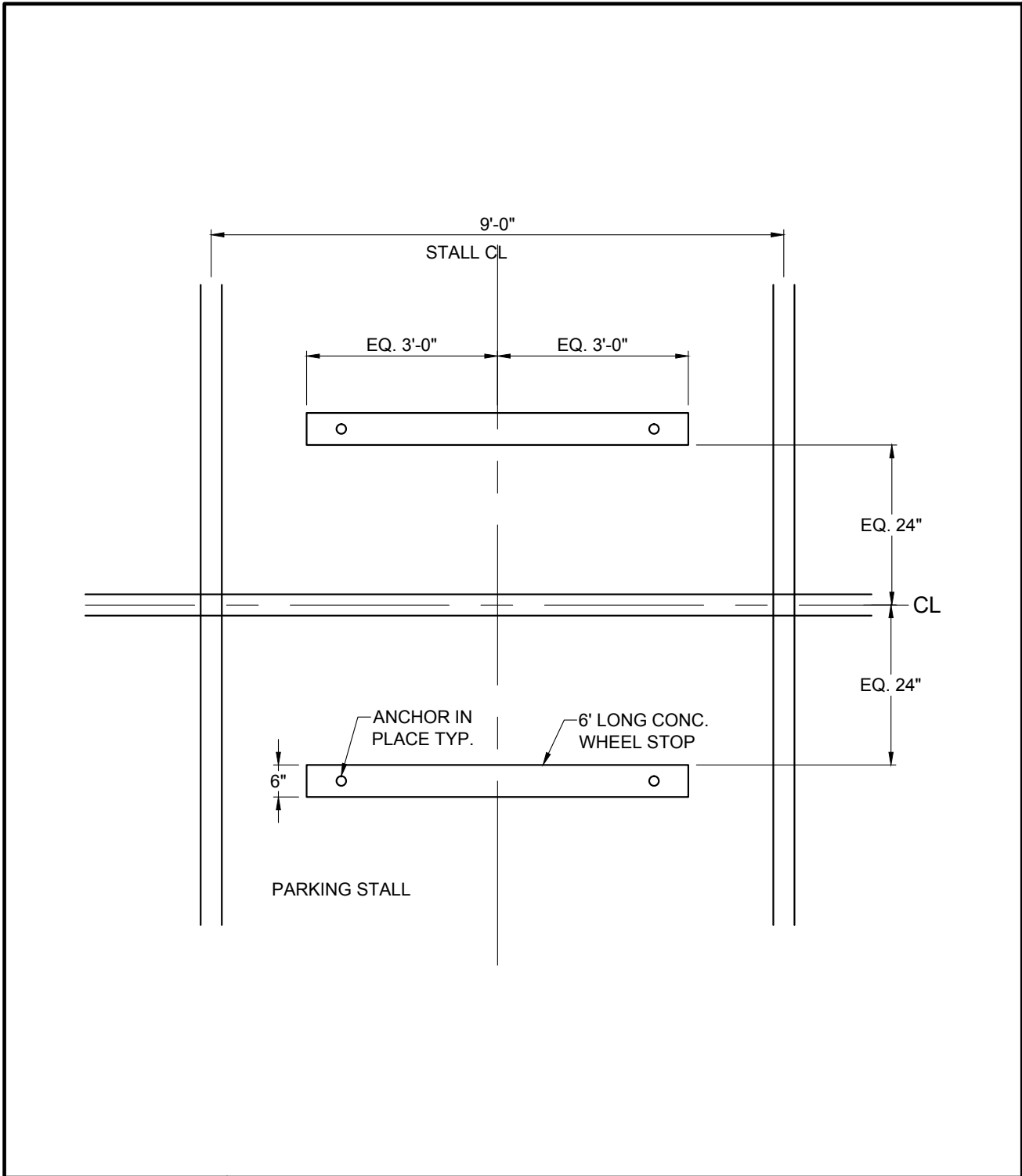

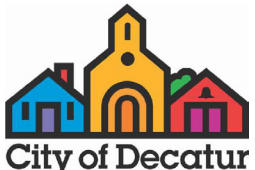
|  |  |  |
|--|--|--|
|  <p>City of Decatur</p> | <p>DECATUR STREETScape GUIDELINES<br/>DOWNTOWN DECATUR</p> |  |
|  | <p>WHEEL STOP</p>  |  |
|  | <p>SCALE: NONE</p>   | <p>DRAFT DATE:<br/>07/03/2014</p> <p>STANDARD NO:<br/><b>401</b></p> |

# Site Furnishings

## Trash Receptacle and Connection

Quote#: sample

7/28/14



**PTRD32D**

P.O. Box 1700 • Hendersonville, NC 28793  
 800-633-8241 • 828-693-8241 tel • 828-693-8777 fax  
 sales@leisurecraftinc.com

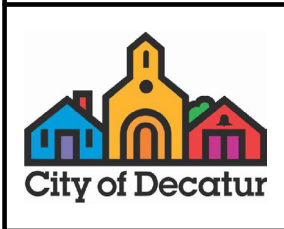

|  |   |
|--|---|
| DECATUR STREETSCAPE GUIDELINES<br>DOWNTOWN DECATUR |   |
| TRASH RECEPTACLE                                   |   |
| SCALE: NONE  | DRAFT DATE:<br>07/03/2014<br>STANDARD NO:<br><b>402</b> |

# Site Furnishings

## Bicycle Rack

**PRODUCT:** 2 $\frac{3}{8}$ " 9 GAUGE SCHEDULE 40 PIPE BIKE DOCK BY SARIS PARKING OR EQUIVALENT APPROVED BY CITY.

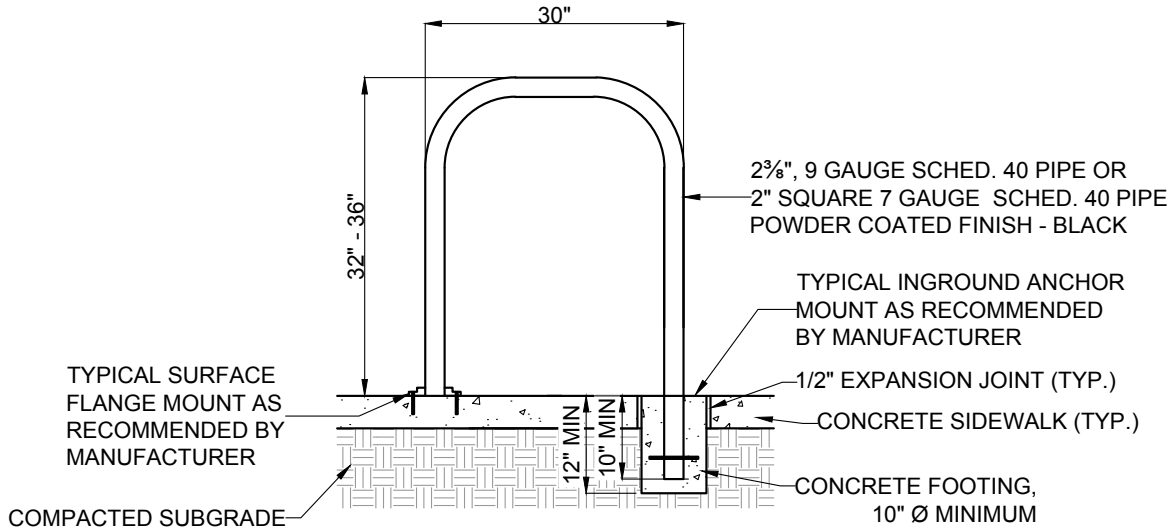

**NOTE:** WHEN MULTIPLE BIKE RACKS ARE INSTALLED, ENSURE RACKS ARE SIMILAR IN HEIGHT AND WIDTH.

### BIKE RACK

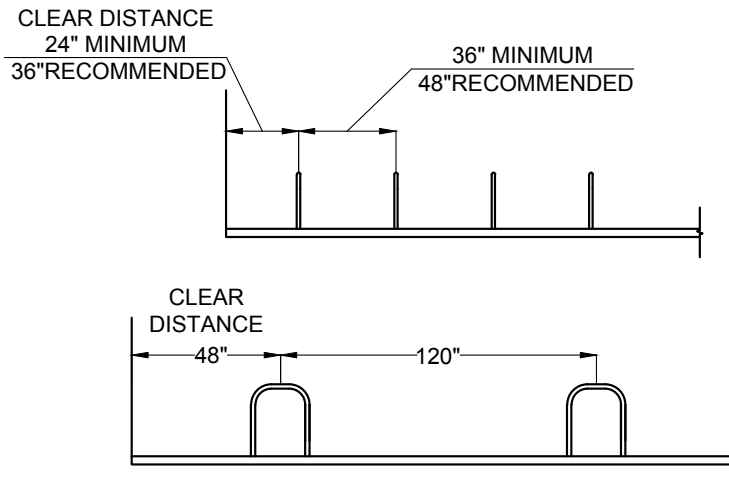

### RECOMMENDED SPACING

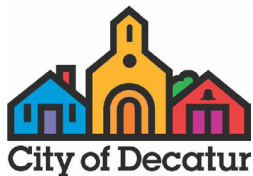

## DECATUR STREETSCAPE GUIDELINES DOWNTOWN DECATUR

### BICYCLE RACK

SCALE: NONE

DRAFT DATE:  
07/03/2014

STANDARD NO:

403

# Site Furnishings

## Ornamental Pedestrian Lights

All Ornamental Pedestrian Lights and associated footings and wiring shall be provided by Georgia Power. Contractor shall be responsible for coordinating the sequencing of the project with Georgia Power.

Contact William Cunningham, Georgia Power Company Lighting Services  
Office: 770-621-2457 Cell: 404-664-7162 Email: wccunnin@southernco.com

There are three different poles and fixtures used within City of Decatur, which are based on project location within the City. Contact the Decatur Design, Environment and Construction Division for information regarding which streetlight is appropriate for a specific property. Information about the pole and fixture to use in the different locations are as follows.



Downtown Decatur

Pole – Ameron Traditional Series  
Victorian II Pole VEF-4.0

Luminaire – Unique Solutions, a  
Division of Holophane, Granville  
Leaf Housing model number  
GV1A050HP12LB3NNON

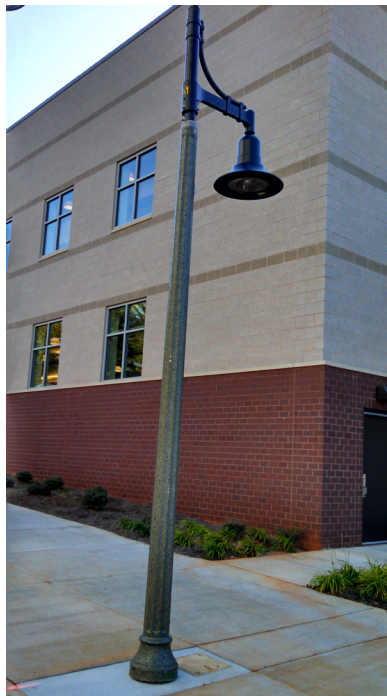

East Decatur District

Pole – Ameron Traditional Series  
Victorian II Pole VEF-4.0

Luminaire – Cooper Lighting,  
catalogue number EMM-100-HPS-  
120-5S-FG-SR-BL-BK-L



Oakhurst Village

Pole – Ameron – Standard VEF04  
Pole with tenon assembly

Luminaire – Streetworks Arc  
Generation Series, catalog  
number ARC15SR23322BK4U

This page intentionally left blank.

# Plantings

## Groundcover and Perennials

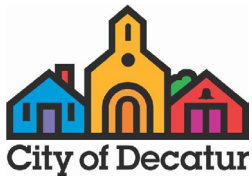
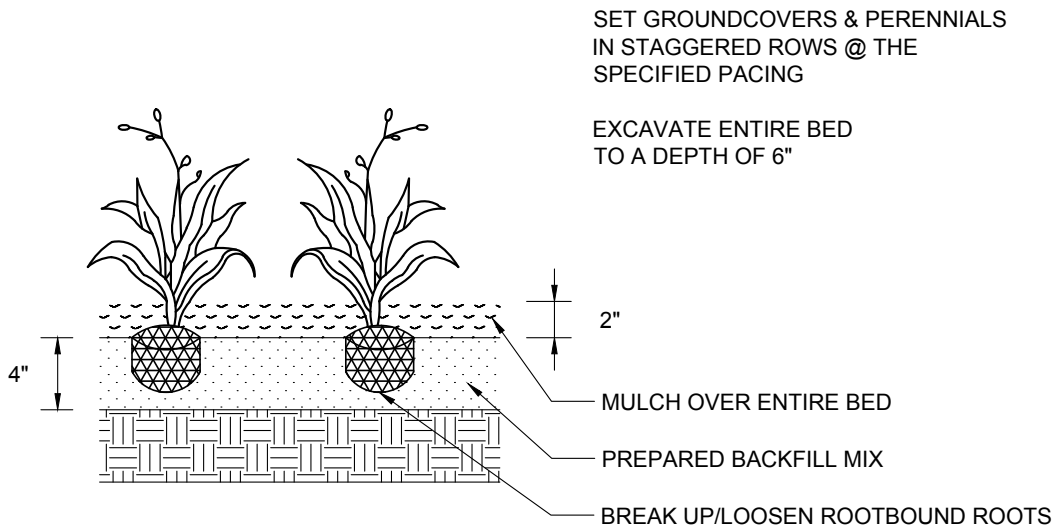

### DECATUR STREETScape GUIDELINES DOWNTOWN DECATUR

#### GROUNDCOVER AND PERENNIALS

SCALE: NONE

DRAFT DATE:  
07/03/2014

STANDARD NO.:

**500**

# Plantings

## Triangular Plant Spacing

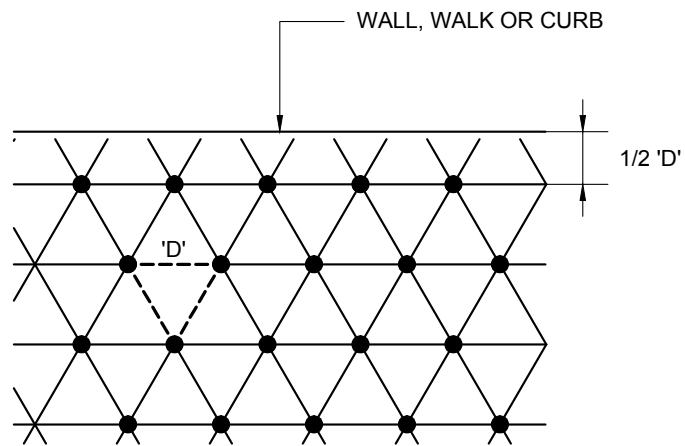

NOTE:  
SPACE PLANTS EQUIDISTANT FROM EACH OTHER AS SHOWN ABOVE  
  
'D' SPACING AS NOTED ON PLAN FOR GROUNDCOVER AND PERENNIALS

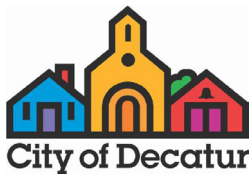

DECATUR STREETSCAPE GUIDELINES  
DOWNTOWN DECATUR

TRIANGULAR PLANT SPACING

SCALE: NONE

DRAFT DATE:  
07/03/2014

STANDARD NO:  
**501**



# Plantings

## Sidewalk Tree Well Section

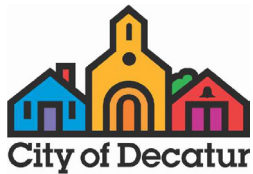
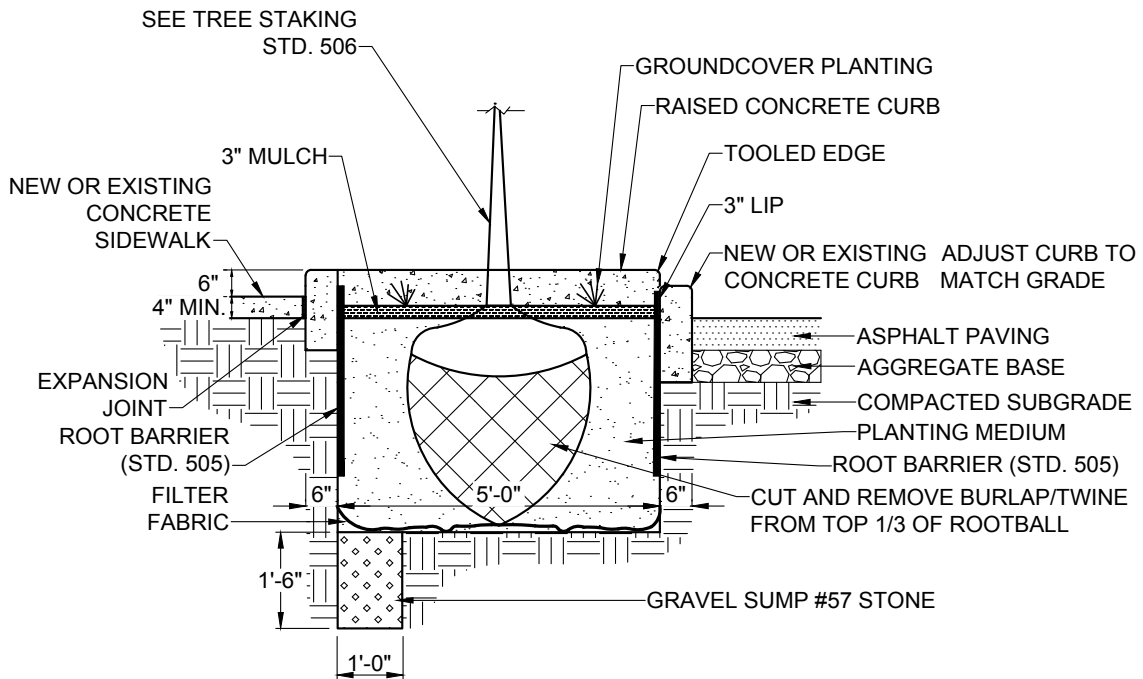

### DECATUR STREETScape GUIDELINES DOWNTOWN DECATUR

#### SIDEWALK TREE WELL SECTION

SCALE: NONE

DRAFT DATE:  
07/03/2014

STANDARD NO:

**502**

# Plantings

## Parking Area Tree Well Section

NOTE: TREE STAKING  
SIMILAR TO STD. 506

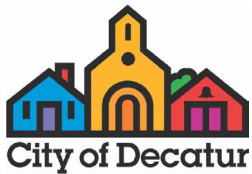
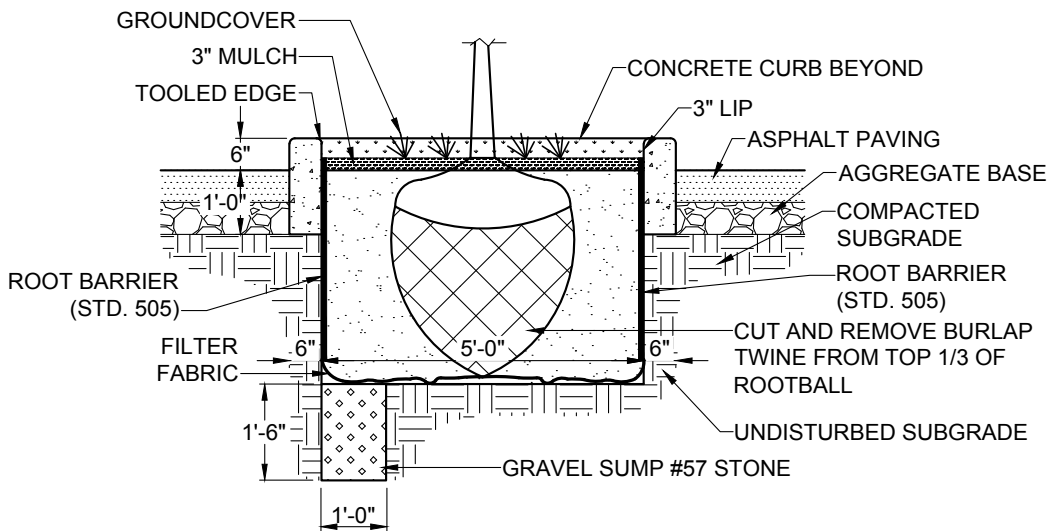

### DECATUR STREETScape GUIDELINES DOWNTOWN DECATUR

#### PARKING AREA TREE WELL SECTION

SCALE: NONE

DRAFT DATE:  
07/03/2014

STANDARD NO:

**503**

# Plantings

## Temporary Tree Protection

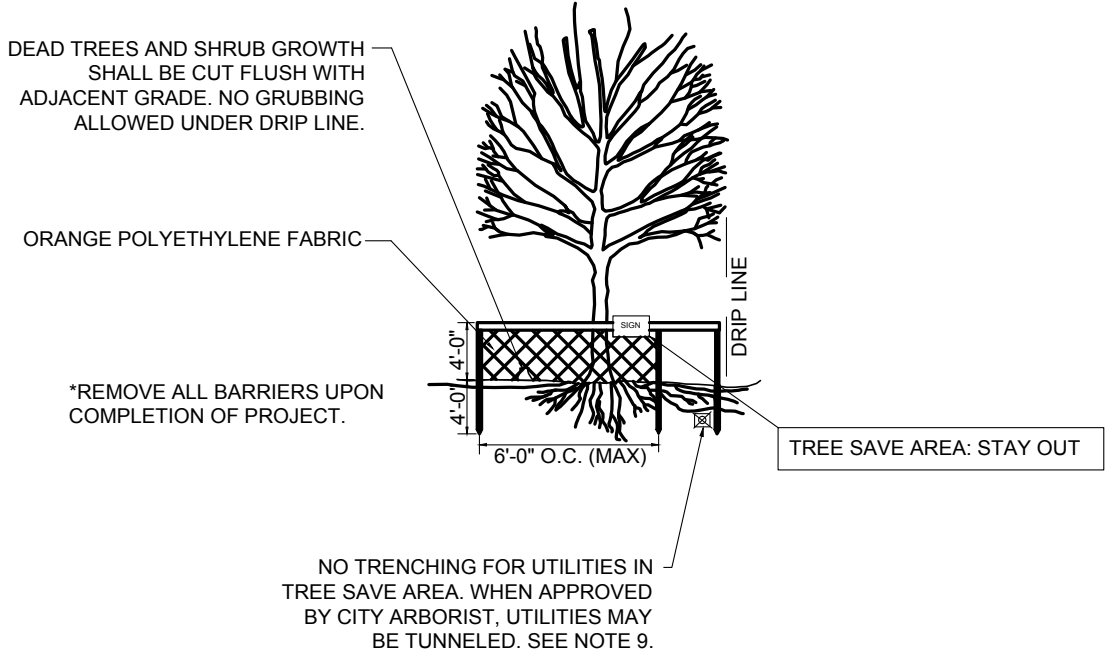

- NOTE:**
1. ROOT PROTECTION ZONE SHALL BE DEFINED AS A RADIUS EQUAL TO 1.25 TIMES THE TREES DIAMETER AT BREAST HEIGHT OR DRIPLINE LIMITS, WHICHEVER IS GREATER.
  2. FENCE OF THE ROOT PROTECTION ZONE SHALL BE 4-FOOT HIGH ORANGE POLYETHYLENE FABRIC ATTACHED TO WOODEN STAKES, 2"x4"x8' STANDARDS. INSTALL FENCE PRIOR TO ALL CONSTRUCTION ACTIVITY, INCLUDING MOVING EQUIPMENT AND TRAILERS ONTO THE SITE.
  3. TREE SAVE AREA SIGNS TO BE IN ENGLISH AND SPANISH (SALVE UN ARBOL). SIGNS SHALL BE SPACED EVERY 20' OR A MINIMUM OF 4 SIGNS PER SPECIMEN TREE.
  4. ANY ROOT OR BRANCH PRUNING SHALL BE DONE ONLY BY A CERTIFIED AND LICENSED ARBORIST.
  5. NO GRADE CHANGE IS TO OCCUR IN TREE SAVE AREA. DO NOT DISTURB ORIGINAL GRADE.
  6. NO TREE WELLS OR AERATION SYSTEM.
  7. MAINTAIN FENCE BY REPAIRING AND/OR REPLACING DAMAGED FENCE. DO NOT REMOVE FENCE PRIOR TO LANDSCAPING OPERATIONS.
  8. DO NOT STORE OR STACK MATERIALS, EQUIPMENT, OR VEHICLES WITHIN FENCED AREA.
  9. IF APPROVED BY CITY ARBORIST, TUNNELING WITHIN DRIP LINE SHALL BE PLACED 3 TO 4 FEET DEEP AND AT LEAST 2 FEET AWAY FROM TREES CENTER TO AVOID TAP ROOTS.

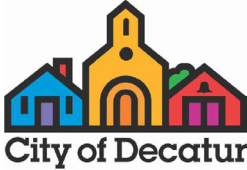
|   |  |  |                           |
|---|--|--|---------------------------|
|  | <b>DECATUR STREETSCAPE GUIDELINES</b><br><b>DOWNTOWN DECATUR</b> |  |                           |
|   | <b>TEMPORARY TREE PROTECTION</b>                                 |  |                           |
|   | SCALE: NONE  | <table border="1"> <tr> <td>DRAFT DATE:<br/>07/03/2014</td> </tr> <tr> <td>STANDARD NO:<br/><b>504</b></td> </tr> </table> | DRAFT DATE:<br>07/03/2014 |
| DRAFT DATE:<br>07/03/2014   |  |  |                           |
| STANDARD NO:<br><b>504</b>  |  |  |                           |

# Plantings

## Root Barrier Details

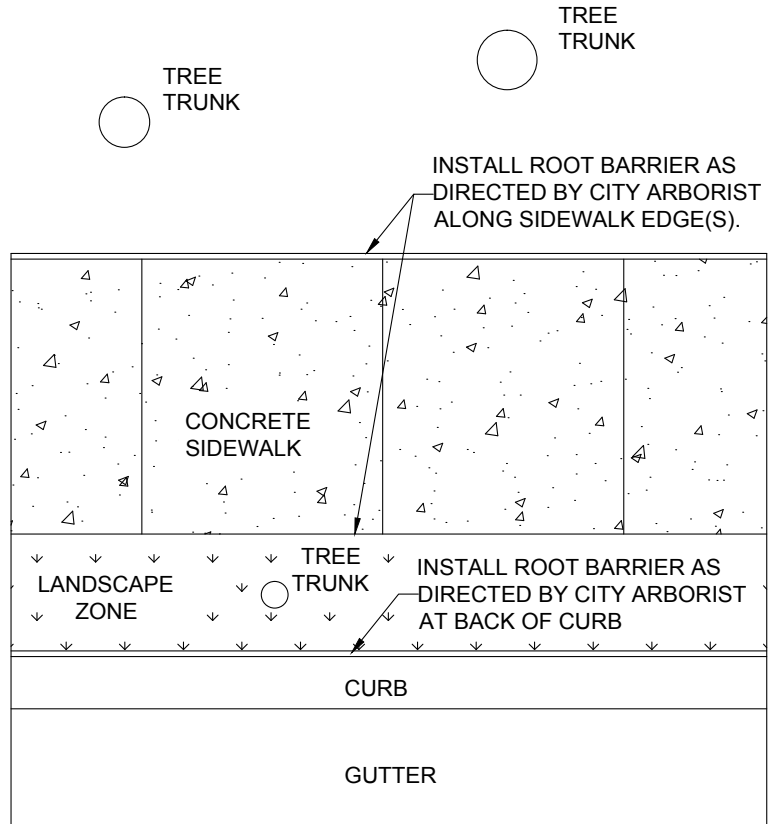

**NOTES:**

1. ROOT BARRIERS SHALL BE REQUIRED FOR ALL TREES WITHIN 10' OF HARDSCAPE WITHIN MAXIMUM EXPECTED CRZ AT MATURITY OR ENTIRE LENGTH OF HARDSCAPE.
2. ROOT BARRIER SHALL BE PRODUCT UB 24 AS MANUFACTURED BY DEEPROOT GREEN INFRASTRUCTURE, LLC, 530 WASHINGTON STREET, SAN FRANCISCO, CA OR EQUIVALENT AS APPROVED BY CITY ARBORIST.
3. TOP OF ROOT BARRIER SHALL BE SET A MINIMUM OF 1/2" +/- ABOVE FINISHED GRADE OF SOIL. HOWEVER, UNDER NO CIRCUMSTANCES SHALL THE TOP OF ROOT BARRIER EXTEND ABOVE ADJACENT CURB, SIDEWALK OR OTHER HARD SURFACING.
4. FURNISH AND INSTALL ROOT BARRIER AS SPECIFIED BY MANUFACTURER.

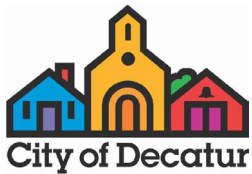

DECATUR STREETScape GUIDELINES  
DOWNTOWN DECATUR

ROOT BARRIER DETAILS

SCALE: NONE

DRAFT DATE:  
07/03/2014

STANDARD NO:

**505**

# Plantings

## Tree Staking Standards

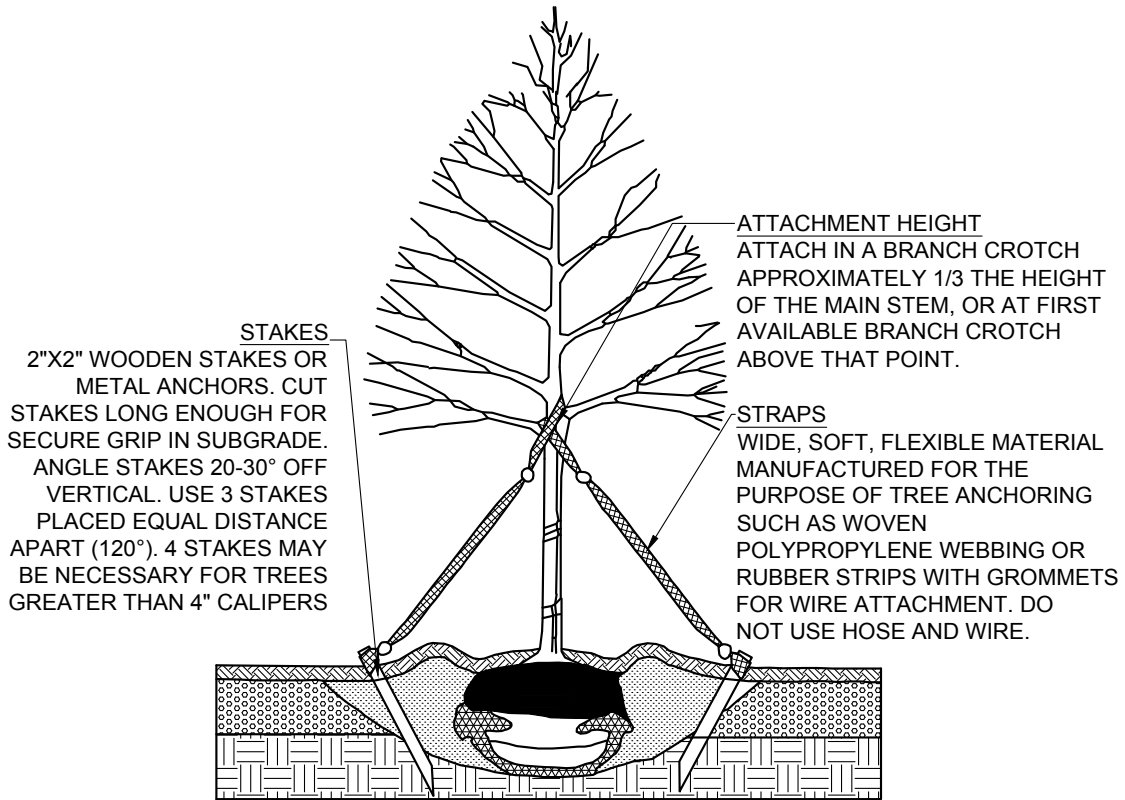

USE ANCHORING SYSTEMS ONLY WHERE WIND OR SOIL CONDITIONS MAKE IT NECESSARY OR AS REQUIRED BY CITY ARBORIST. REMOVE AFTER ONE YEAR.

**ALTERNATE TREE STABILIZATION:**

WHEN APPROVED BY THE CITY ARBORIST, IN HIGH TRAFFIC/DOWNTOWN AREAS ROOT STAPLES OR TREE STAPLES MAY BE INSTALLED IN ACCORDANCE WITH MANUFACTURER SPECIFICATIONS.

PRODUCT: TREE STAPLE BY TREE STAPLE, INC. OR EQUIVALENT APPROVED BY CITY ARBORIST.

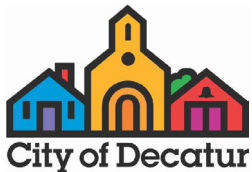

DECATUR STREETScape GUIDELINES  
DOWNTOWN DECATUR

TREE STAKING STANDARDS

SCALE: NONE

DRAFT DATE:  
07/03/2014

STANDARD NO:

**506**

# Plantings

## Appropriate Plant Selections

Tree selections are suggested but not limited to the listed trees. Alternate selections may be used with the arborist's approval. The size and type of planting area (e.g., tree well, planting strip, landscape island, etc.), proximity of utility lines and similar factors should be considered in choosing the proper tree.

### STREET TREES (Minimum of 3.5 inch caliper measured 6 inches above the ground)

| COMMON NAME     | BOTANICAL NAME                     | CHARACTER    |
|-----------------|------------------------------------|--------------|
| Princeton Elm   | <i>Ulmus americana</i> "Princeton" | Large canopy |
| Willow Oak      | <i>Quercus phellos</i>             | Large canopy |
| Nuttall Oak     | <i>Quercus nuttalli</i>            | Large canopy |
| Shumard Oak     | <i>Quercus shumardii</i>           | Large canopy |
| Swamp White Oak | <i>Quercus bicolor</i>             | Large canopy |

### UNDERSTORY TREES (Minimum of 2 inch caliper or 6 feet height)

| COMMON NAME                | BOTANICAL NAME                 | CHARACTER                |
|----------------------------|--------------------------------|--------------------------|
| Trident Maple              | <i>Acer buergeranum</i>        | Single trunk             |
| Flowering Dogwood          | <i>Cornus florida</i>          | Single trunk             |
| Kousa Dogwood              | <i>Cornus kousa chinensis</i>  | Single trunk             |
| Fringe Tree                | <i>Chinonthus virginicus</i>   | Multi-trunk/Single trunk |
| Eastern Redbud & varieties | <i>Cercis Canadensis</i>       | Multi-trunk/Single trunk |
| Serviceberry               | <i>Amelanchier arborea</i>     | Multi-trunk/Single trunk |
| Purple Smoke Tree          | <i>Cotinus obovatus</i>        | Multi-trunk/Single trunk |
| Crape Myrtle               | <i>Lagerstroemia - various</i> | Multi-trunk/Single trunk |

### SHRUBS

| COMMON NAME          | BOTANICAL NAME               | SIZE / CALIPER     |
|----------------------|------------------------------|--------------------|
| Gumpo Azalea         | <i>Azalea hybrid</i>         | 3 gallon / 18 inch |
| Indian Azalea        | <i>Azalea x indica</i>       | 3 gallon / 18 inch |
| Beautyberry          | <i>Clicorpa americana</i>    | 3 gallon / 30 inch |
| Clethra              | <i>Clethra alnifolia</i>     | 3 gallon / 30 inch |
| Fothergilla          | <i>Fothergilla gardenia</i>  | 3 gallon / 30 inch |
| Dwarf Yaupon Holly   | <i>Ilex vomitoria 'nana'</i> | 3 gallon / 24 inch |
| Virginia Willow/Itea | <i>Itea virginica</i>        | 3 gallon / 30 inch |
| Winterberry          | <i>Ilex verticillata</i>     | 3 gallon / 30 inch |

# Plantings

## Appropriate Plant Selections (continued)

### GROUNDCOVER

| COMMON NAME          | BOTANICAL NAME                | SIZE / CALIPER |
|----------------------|-------------------------------|----------------|
| Blue Fescue          | <i>Festuca glauca</i>         | 1 gallon       |
| Blue Pacific Juniper | <i>Juniperus conferta</i>     | 3 gallon       |
| Big Blue Liriope     | <i>Liriope muscari</i>        | 1 gallon       |
| Purple Love Grass    | <i>Eragrostis spectabilis</i> | 1 gallon       |
| Appalachian Sedge    | <i>Carex appalachia</i>       | 4 inch pot     |
| Pennsylvania Sedge   | <i>Carex Pennsylvania</i>     | 4 inch pot     |
| White tinged Sedge   | <i>Carex albicans</i>         | 4 inch pot     |
| Mondo Grass          | <i>Ophiopogon japonicus</i>   | 4 inch pot     |



Photographs of Typical Plant Selections

This page intentionally left blank.



# Drainage

## Curved Bicycle Safety Grate

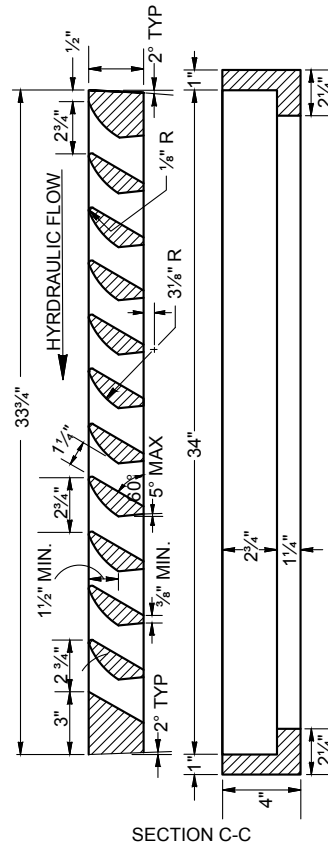
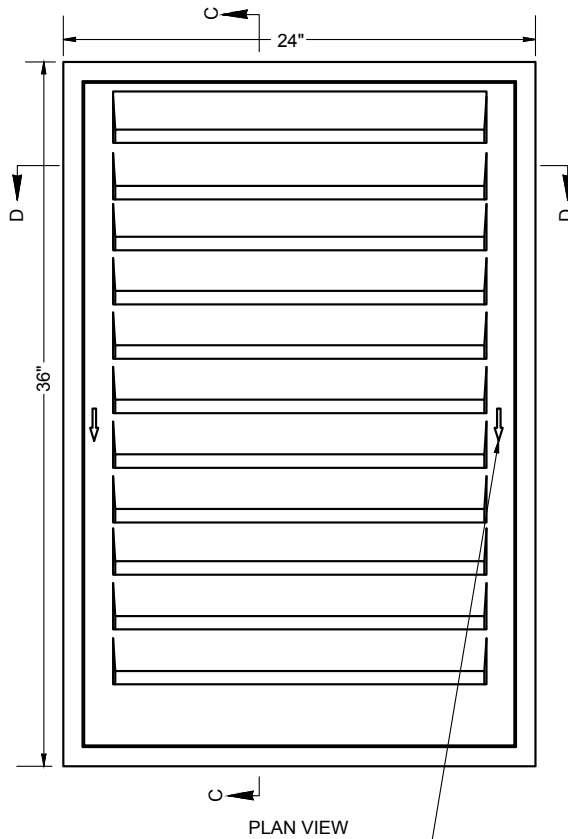
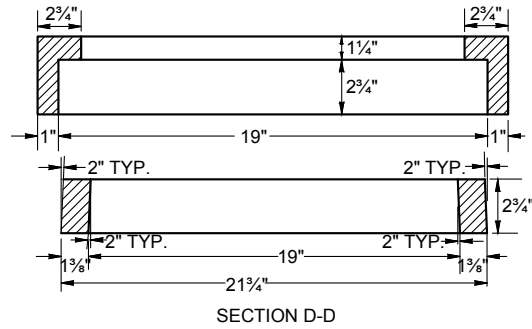

RAISED OR RECESSED  
ARROWS INDICATE DIRECTION OF  
HYDRAULIC FLOW. DESIGN OF ARROWS  
IN MANUFACTURER'S CHOICE.

**NOTE:**  
ALL TYPE DROP INLETS WILL BE CONSTRUCTED (AS  
SHOWN), SO THAT THE GRATE BARS ARE  
PERPENDICULAR TO THE FLOW OF TRAFFIC EXCEPT ON  
LIMITED ACCESS PROJECTS OR WHERE BICYCLES ARE  
PROHIBITED.

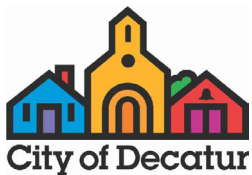

### DECATUR STREETSCAPE GUIDELINES DOWNTOWN DECATUR

#### CURVED BICYCLE SAFETY GRATE

SCALE: NONE

DRAFT DATE:  
07/03/2014

STANDARD NO:

**601**

# Drainage

## Sidewalk Flume with Plate and Sidewalk Trench Frame and Grate

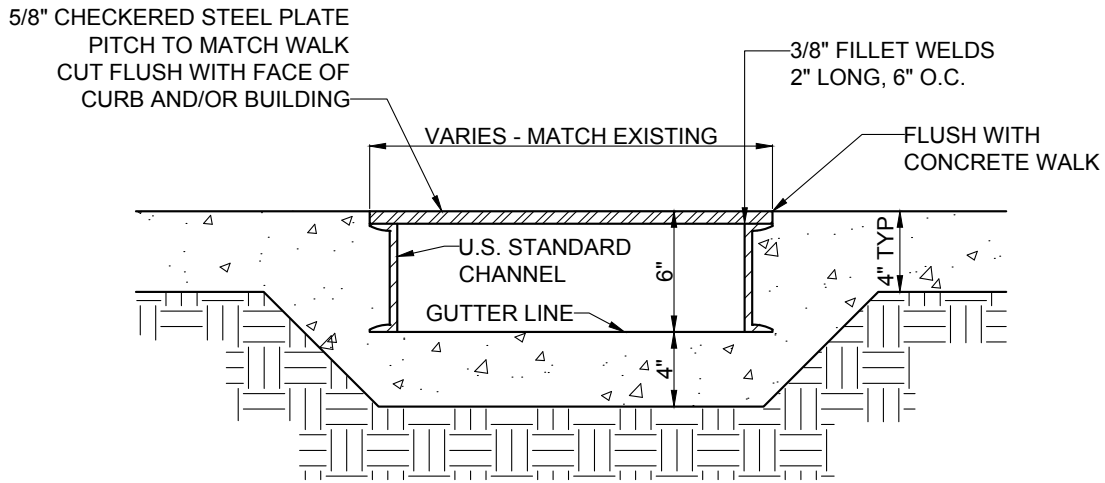

SIDEWALK FLUME WITH PLATE

Sidewalk Flume/Drain Grate & Frame:

A. Model: "Wave" by Urban Accessories, P.O. Box 310, 20004 144th Street, N.E., Woodinville, WA 98072

B. Size: 8"W x 18"L

Color and Finish: Flume/Grate and Frame at Natural Raw Metal

Frame: Model P-Paver



TRENCH FRAME AND GRATE

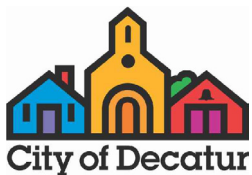

### DECATUR STREETScape GUIDELINES DOWNTOWN DECATUR

#### SIDEWALK FLUME WITH PLATE AND SIDEWALK TRENCH FRAME AND GRATE

SCALE: NONE

DRAFT DATE:  
07/03/2014

STANDARD NO:

**602**

# Drainage

## Flared End Section

CONCRETE FLARED END SECTIONS SHALL BE IN ACCORDANCE WITH GEORGIA DEPARTMENT OF TRANSPORTATION (GDOT) CONSTRUCTION STANDARD 1120.

### CONCRETE FLARED END SECTION

|                  | PIPE DIAMETER, in (mm) |            |            |             |             |             |
|------------------|------------------------|------------|------------|-------------|-------------|-------------|
| Diameter in (mm) | 12 (300)               | 15 (375)   | 18 (450)   | 24 (600)    | 30 (750)    | 36 (900)    |
| A in (mm)        | 6.5 (165)              | 6.5 (165)  | 7.5 (191)  | 7.5 (191)   | 7.5 (191)   | 7.5 (191)   |
| B (max) in (mm)  | 10.0 (254)             | 10.0 (254) | 15.0 (381) | 18.0 (475)  | 22.0 (559)  | 25.0 (635)  |
| H in (mm)        | 6.5 (165)              | 6.5 (165)  | 6.5 (165)  | 6.5 (165)   | 8.6 (218)   | 8.6 (218)   |
| L in (mm)        | 25.0 (635)             | 25.0 (635) | 32.0 (813) | 36.0 (914)  | 58.0 (1473) | 58.0 (1473) |
| W in (mm)        | 29.0 (737)             | 29.0 (737) | 35.0 (889) | 45.0 (1143) | 63.0 (1600) | 63.0 (1600) |

**GENERAL NOTES:**

- 12- THROUGH 36-INCH (300 TO 900MM) FLARED END SECTIONS FOR USE IN CULVERT AND DRAINAGE OUTLET APPLICATIONS FOR CORRUGATED HDPE PIPE. HDPE FLARED END SECTIONS ARE ONLY TO BE USED WITH HDPE PIPE.
- THE INVERT OF THE PIPE AND THE END SECTION SHALL BE AT THE SAME ELEVATION AS THE FLARED END SECTION AND SHALL BE HIGH DENSITY POLYETHYLENE MEETING ASTM D3350-00 WITH A MINIMUM CELL CLASSIFICATION OF 213320C. EACH END SECTION SHALL HAVE A CARBON BLACK ADDITIVE FOR UV PROTECTION. WHEN PROVIDED, THE METAL THREADED FASTENING ROD SHALL BE STAINLESS STEEL.
- INSTALLATION SHALL BE IN ACCORDANCE WITH THE MANUFACTURER INSTRUCTIONS AND THOSE ISSUED BY THE STATE OR LOCAL AUTHORITIES.
- CENTERLINE OF FLARED END SECTION WILL ALIGN WITH CENTERLINE OF PIPE. IF PIPE IS SKEWED, THE EMBANKMENT SLOPE WILL BE WARPED TO CONFORM WITH END SECTION.
- WHERE HDPE FLARED END SECTIONS ARE USED WITH MULTIPLE PIPELINES, THE STANDARD SPACING BETWEEN PIPES MAY HAVE TO BE INCREASED TO PREVENT OVERLAP OF END SECTION WINGTIPS.

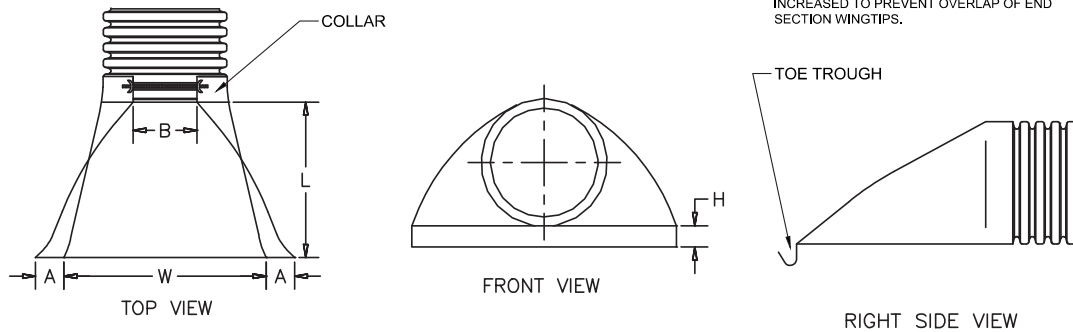

### HDPE FLARED END SECTION

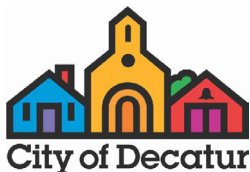

## DECATUR STREETSCAPE GUIDELINES DOWNTOWN DECATUR

### FLARED END SECTION

SCALE: NONE

DRAFT DATE:  
07/03/2014

STANDARD NO:

**603**

# Drainage

## Traffic Rated Manhole Frame and Cover Assembly

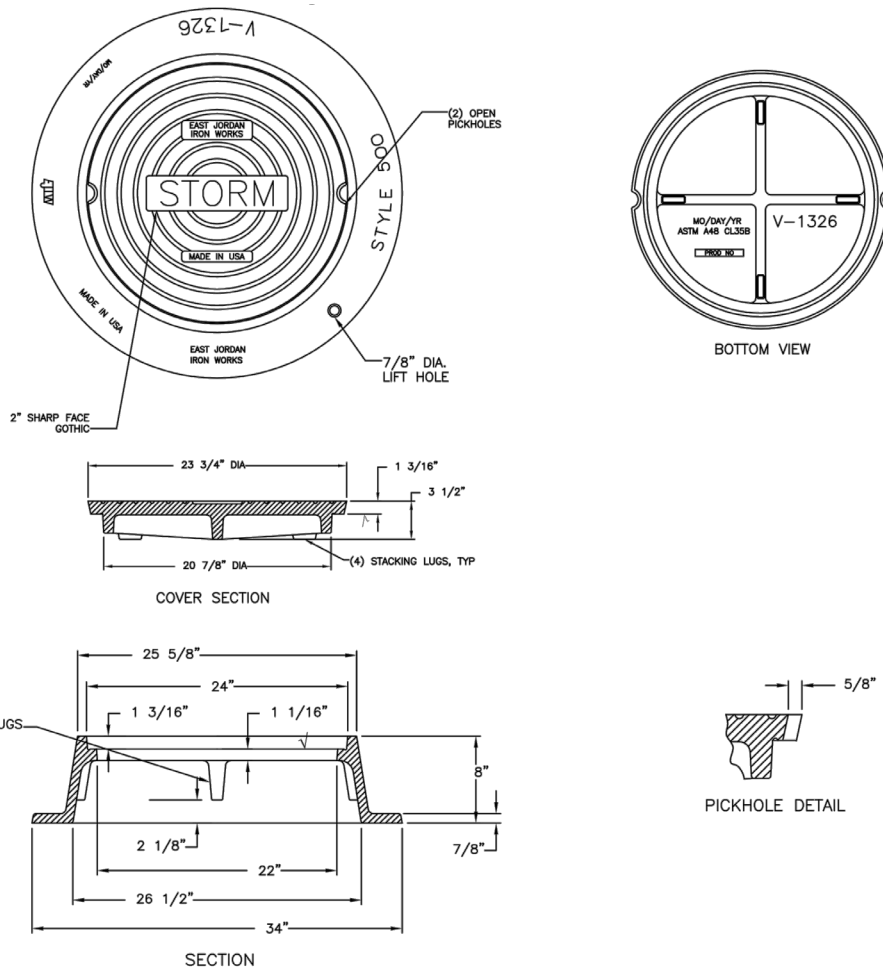

**NOTES:**

1. MANHOLE FRAME AND COVER ASSEMBLY SHALL BE MODEL NUMBER V1326, AS MANUFACTURED BY EAST JORDAN IRON WORKS, INCORPORATED, OR APPROVED EQUAL
2. COVER AND FRAME SHALL CONFORM TO A.S.T.M. SPECIFICATIONS A48 LATEST REVISION FOR CLASS 35B GRAY IRON CASTING
3. TRAFFIC-RATED GDOT APPROVED FRAME AND COVER TO BE USED

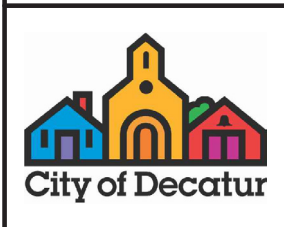

DECATUR STREETSCAPE GUIDELINES  
DOWNTOWN DECATUR

TRAFFIC RATED MANHOLE FRAME AND COVER ASSEMBLY  
SCALE: NONE

DRAFT DATE:  
07/03/2014

STANDARD NO:  
**604**

# Drainage

## Non-Traffic Rated Manhole Frame and Cover Assembly

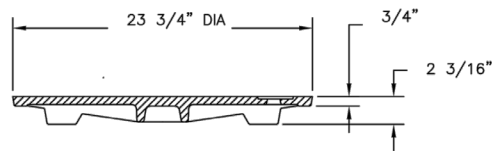
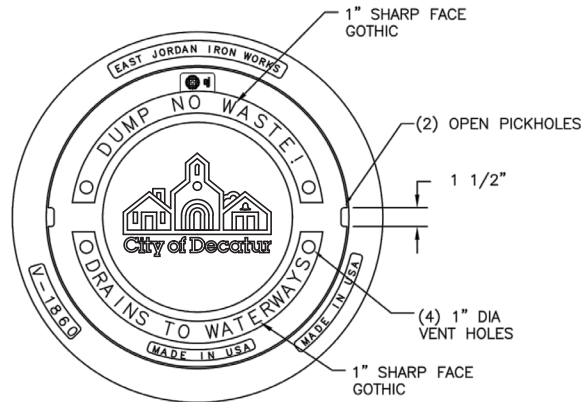

COVER SECTION

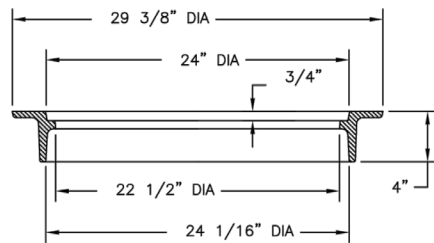

FRAME SECTION

NOTES:

1. MANHOLE FRAME AND COVER ASSEMBLY SHALL BE MODEL NUMBER V1860 WITH CITY OF DECATUR LOGO, AS MANUFACTURED BY EAST JORDAN IRON WORKS, INCORPORATED, OR APPROVED EQUAL
2. COVER AND FRAME SHALL CONFORM TO A.S.T.M. SPECIFICATIONS A48 LATEST REVISION FOR CLASS 35B GRAY IRON CASTING
3. STORM MANHOLE TO ONLY BE USED IN NON-TRAFFIC AREAS

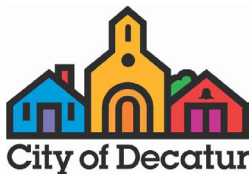

DECATUR STREETSCAPE GUIDELINES  
DOWNTOWN DECATUR

NON-TRAFFIC RATED MANHOLE FRAME  
AND COVER ASSEMBLY

SCALE: NONE

DRAFT DATE:  
07/03/2014

STANDARD NO:

605

# Drainage

## Bioswale Planter Detail

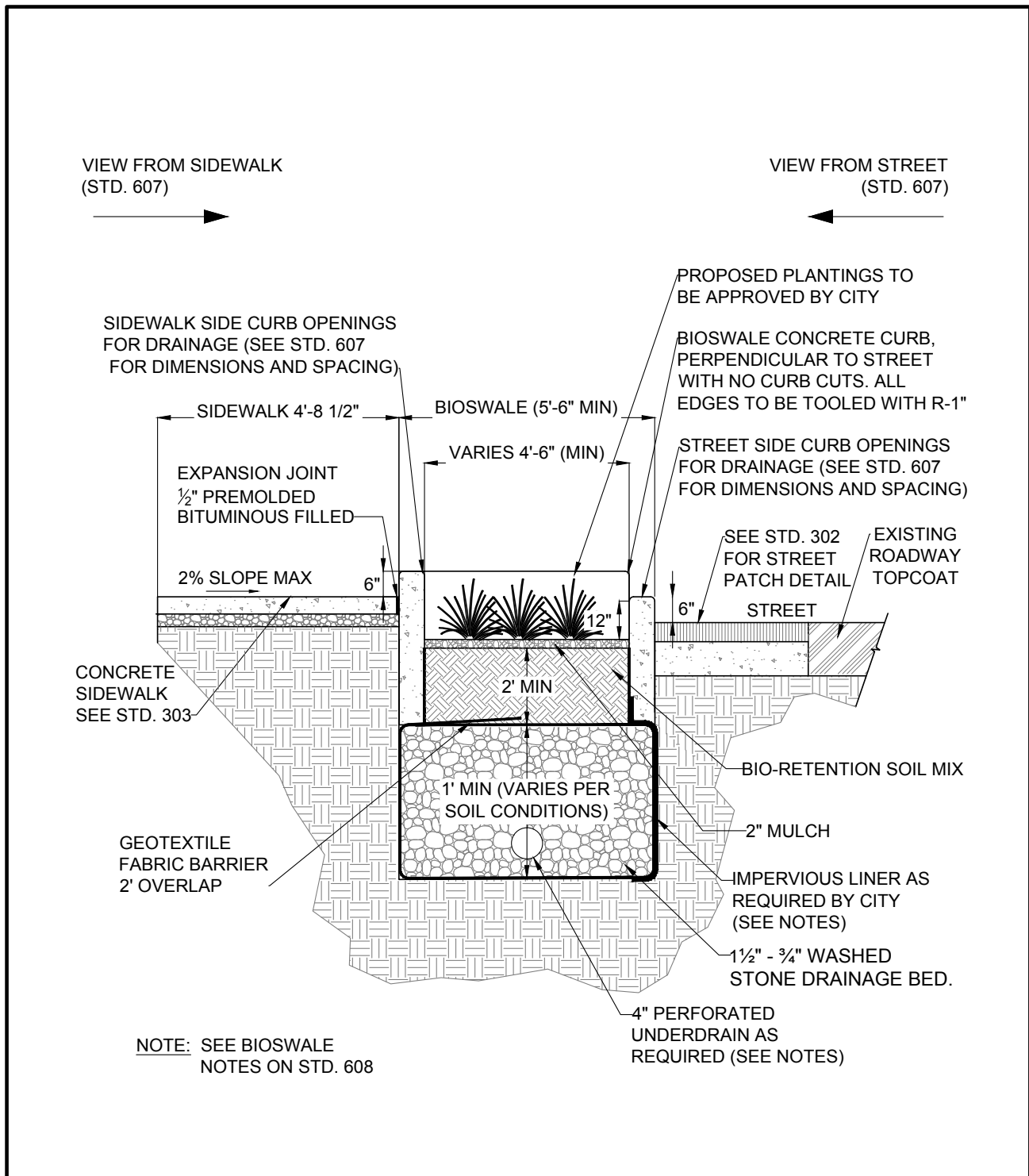

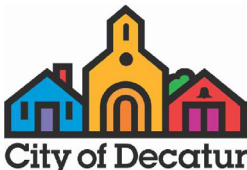
|   |  |   |
|---|--|---|
|  | DECATUR STREETScape GUIDELINES<br>DOWNTOWN DECATUR |   |
|   | BIOSWALE PLANTER DETAIL                            | DRAFT DATE:<br>07/03/2014<br>STANDARD NO:<br><b>606</b> |
| SCALE: NONE   |  |   |

# Drainage

## Bioswale Planter Curb Openings Detail

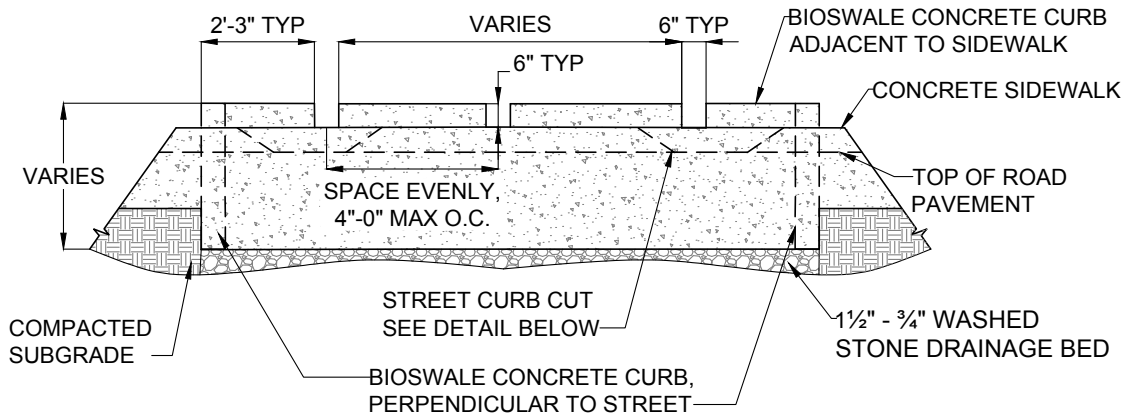

VIEW FROM SIDEWALK

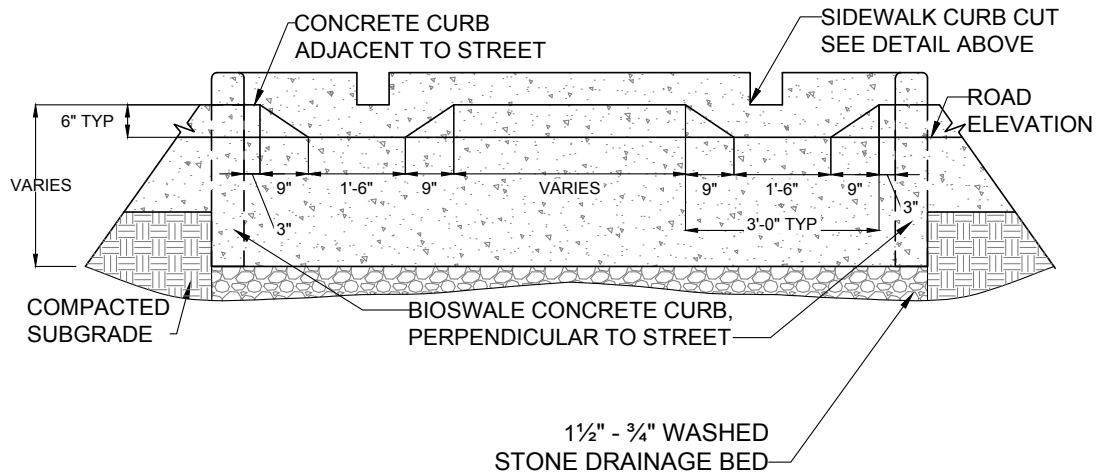

VIEW FROM STREET

NOTE: CURBS MATCH SLOPES OF ADJACENT ROAD OR SIDEWALK UNLESS OTHERWISE INDICATED ON PLANS.

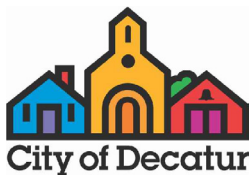

DECATUR STREETSCAPE GUIDELINES  
DOWNTOWN DECATUR

BIOSWALE PLANTER CURB OPENINGS DETAIL

SCALE: NONE

DRAFT DATE:  
07/03/2014

STANDARD NO:

607

# Drainage

## Bioswale Planter Notes

NOTES FOR BIOSWALE PLANTERS:

1. MAXIMUM PONDING DEPTH IN BIOSWALE SHALL NOT BE GREATER THAN SIX INCHES.
2. WIDTH AND LENGTH OF PLANTER AND DEPTH OF BIORETENTION SOIL MIX AND WASHED STONE DRAINAGE BED MAY VARY DUE TO SITE CONDITIONS AND STORMWATER TREATMENT VOLUME.
3. LOCATE ALL UTILITIES PRIOR TO DESIGN. SITE CONDITIONS WILL VARY AND SIGNIFICANT DESIGN ADAPTATIONS MAY BE NEEDED TO ADDRESS UTILITY CONFLICTS, STEEP SLOPES, AND OTHER CONSTRAINTS.
4. CROSS SLOPES SHOULD ALWAYS BE AS CLOSE TO LEVEL (0% SLOPE) AS POSSIBLE.
5. CURBS, GUTTERS, STREETS, AND SIDEWALKS SHALL CONFORM TO CITY OF DECATUR STANDARDS.
6. PLANS SHALL INDICATE ELEVATIONS AT ALL INLETS AND OUTLETS, AS WELL AS ALL GRADES ON STREET AND BOTTOM OF PLANTER.
7. SIDEWALK ELEVATION MUST BE HIGHER THAN MAXIMUM FLOW OR POOL ELEVATION.
8. PLANTERS MUST BE ABLE TO WITHSTAND STORMWATER FLOWS WITHOUT EROSION OR OTHER DAMAGE . INLETS SHOULD BE SIZED AND CHECK DAMS USED TO ENSURE APPROPRIATE VELOCITIES.
9. ALL VEGETATED AREAS MUST BE MULCHED WITH EITHER 2-3" OF NON FLOATABLE ORGANIC MULCH (SUCH AS SHREDDED HARDWOOD OR LEAF MOULD) OR STONE. STONE MULCH MAY BE NEEDED IN AREAS OF STRONG FLOWS TO PREVENT EROSION. ALL PONDING ELEVATIONS SHOWN IN DETAILS ARE ASSUMED TO BE MEASURED FROM TOP OF MULCH LAYER.
10. BIORETENTION SOIL MIX SHALL BE SANDY LOAM, LOAMY SAND, OR LOAM TEXTURE WITH CLAY CONTENT RANGING FROM 10 TO 25%. THE SOIL MUST HAVE AN INFILTRATION RATE OF AT LEAST 0.5 INCHES PER HOUR AND A pH BETWEEN 5.5 AND 6.5. IN ADDITION, THE PLANTING SOLID SHOULD HAVE A 1.5 TO 3% ORGANIC CONTENT AND A MAXIMUM 500 ppm CONCENTRATION OF SOLUBLE SALTS.
11. BIORETENTION SOIL MUST BE A MIN. OF 24" DEEP AT SHALLOWEST POINT. 36" DEPTH IS REQUIRED FOR PLANTING TREES.
12. IF INFILTRATION TESTS IN SOILS AT BOTTOM OF PLANTER SHOW SATURATED INFILTRATION RATES OF LESS THAN ½ INCH PER HOUR (1 FOOT /DAY), UNDERDRAINS SHALL BE REQUIRED.UNDERDRAINS SHALL CONNECT TO STORM DRAINAGE SYSTEM AND/OR RELEASE AT GRADE. UNDERDRAINS SHALL BE SLOPED AT A 1% MINIMUM TO MAINTAIN POSITIVE DRAINAGE.

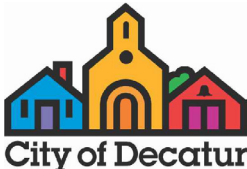
|  |  |  |
|--|--|--|
|  <p>City of Decatur</p> | <p>DECATUR STREETScape GUIDELINES<br/>DOWNTOWN DECATUR</p> |  |
|  | <p>BIOSWALE PLANTER NOTES</p> <p>SCALE: NONE</p>           | <p>DRAFT DATE:<br/>07/03/2014</p> <p>STANDARD NO:<br/><b>608</b></p> |